

THE BAKER COMPANY

Available in Console, and Space-Saver Models. Exceeds ISO-14644 ISO Class 5 (Class 100) Requirements.

EdgeGARD®



EdgeGARD® Console Model

Featuring Unique High Velocity Return Air Slots

EdgeGARD® is a horizontal laminar flow clean bench which provides a HEPA-filtered airflow across the work area, and a particulate-free work surface.

Because only HEPA-filtered air crosses the work surface, the cabinet is ideal for a range of life science and industrial laboratory and process applications where clean air and product protection are essential.

Applications

- IV admixture preparation
- Drug compounding
- Plant cell culture
- Media preparation
- Pharmaceutical procedures
- Electronic assembly
- Limited experimental research

Note: Protects product only; does not contain aerosols generated in the work area, and does not protect personnel or the environment.

Features

Each EdgeGARD® cabinet receives 13 separate performance tests prior to shipment, including complete filter leak tests. A test report accompanies each EdgeGARD® upon delivery.

- High velocity return air slots maximize product protection and ensure ISO Class 5 (Class 100) cleanliness.
- All models feature non-glare, all stainless steel work surfaces and side walls.
- A high performance airflow system provides laminar airflow across the work surface.
- HEPA supply filter with 99.99% minimum efficiency in capturing 0.3 micrometer particulates.



CSA
Listed



Underwriter
Laboratories
Listed



High Velocity Return Air Slots Capture Backwash Air

Cleanliness and product protection are accomplished with precise control of airflow volumes and velocities. A unique feature in the Baker cabinet design, the high velocity return air slots, have been proven to maximize the clean bench protective capabilities.

- High velocity return air slots are located along the front edge and side walls of the work area.
- Location of the return air slots protects from backwash of dirty air into the work area created when instruments, labware or the user's hands and arms are placed within the air stream on the work surface.
- Air is drawn into these slots at high velocity, ensuring that no unfiltered air enters the work area.
- Recovered air is HEPA-filtered before being passed through the work area.
- Because recirculated air reduces the percentage of dirty air passed through the filter, overall filter life is extended.

HEPA Supply Filter With Prefilter

Because filters remove microorganisms and airborne particulates (generally called aerosols) from the air, the quality, performance and useful life of HEPA filters are critical considerations in the clean bench environment.

- Each Baker clean bench filter is scan tested for leaks and tested for overall efficiency by the manufacturer, then individually scan tested by Baker after installation to assure leak-free performance with increased trapping efficiency.

EdgeGARD® Clean Bench

- 1 High velocity return air slots maximize protective capabilities.
- 2 Fluorescent lighting for 200 foot-candle illumination on work surface.
- 3 Externally mounted, independent ground-fault circuit interrupt (GFCI) outlets with self-resetting circuit breaker for user safety.
- 4 Removable protective screen protects HEPA filter.
- 5 Non-glare work surface.
- 6 StediVOLT® voltage regulator automatically adjusts to typical low and high voltage situations to maintain proper airflow.
- 7 Hinged panel for easy cleaning.
- 8 Stainless steel IV bar (optional).
- 9 Plastic storage bins (optional).

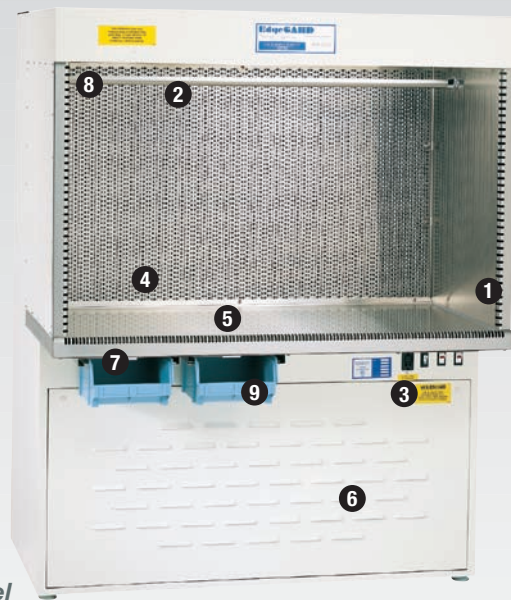

EdgeGARD®
Console Model

Airflow Characteristics

EdgeGARD® employs a laminar airflow across the work surface.

- Clean air is drawn through a prefilter into the base of the console by a blower/motor.
- The prefilter traps dust and larger particles.
- The air is then pushed up the back wall plenum and through a HEPA filter at an average velocity of 100 FPM.
- HEPA-filtered air is directed horizontally across the work surface toward the opening.

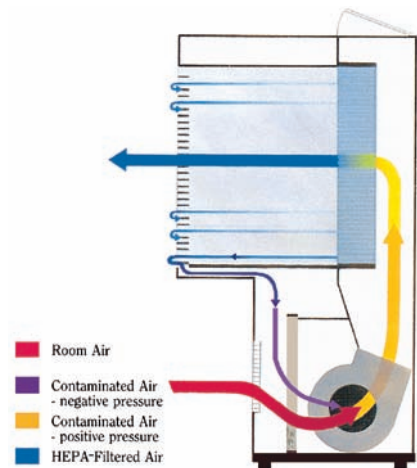

- Minimum filter efficiency is 99.99% for particulates 0.3 micrometers, increased efficiency for particulates greater and smaller than 0.3 micrometers.
- A removable protective screen is located in front of the HEPA filter. The screen protects the filter and is easily removed for cleaning or service.
- The rigid angle steel filter frame is concealed to permit only the filter media to be exposed to the work area, eliminating turbulence created by the frame effect on the rear wall.
- All air is passed through a washable, reusable Scottfoam® prefilter which keeps the HEPA filter free of dust and larger particles, and extends HEPA filter life.

Blower/Motor System Helps Extend Filter Life

Baker has selected an optimum blower/motor combination to assure performance and to extend filter life. The Baker blower/motor provides a volume of air despite increases in resistance due to filter loading, resulting in extremely long filter life as verified by simulated filter loading tests.

Extended filter life minimizes filter replacement costs. The more filter resistance the blower/motor system can overcome, the longer between filter changes.

- As particulates fill the filter media, resistance to airflow increases.
- The Baker blower/motor is a direct drive permanent split capacitor motor designed to deliver the maximum amount of filter life for each cabinet.
- The blower/motor automatically compensates for loading until the filter is fully loaded and motor capacity is reached.

- The filter need not be changed until the blower/motor system cannot deliver adequate air volume to maintain the average velocity of 100 FPM.



StediVOLT® Motor Speed Controller Maintains Optimum Performance

The Baker exclusive StediVOLT® motor speed controller reduces the risk of performance degradation and possible product loss due to typical line voltage fluctuations.

- StediVOLT® minimizes changes in cabinet performance due to routine voltage fluctuations.
- StediVOLT® reads incoming voltage, automatically compensates for low and high voltage, and maintains proper blower speed to prevent periods of unbalanced airflow which may contribute to loss of cleanliness or product protection.

Spacious Work Area With Comfortable Lighting

- The 22" work area depth provides ample space for safe, efficient operation; heights vary from 28½" to 34½", depending on model.
- Each EdgeGARD® clean bench includes fluorescent lamps which provide up to 200 foot-candle lighting at the work surface.
- The warm, natural illumination exhibits better color fidelity.
- Adjustable leg risers (optional) permit work surface heights of 36" and 38".

Electrical System Offers Safety and Convenience

The EdgeGARD® electrical system is designed for safety and convenience.

- An exterior GFCI duplex outlet is provided to accommodate most commonly used instruments and equipment.
- The outlet is provided with a 5 amp self-resetting circuit breaker.
- The outlets are on a separate circuit from the cabinet lights and blower/motor so that an overload caused by equipment will not affect cabinet function.
- For safety reasons, the EdgeGARD® utilizes a single power cord and plug (or junction box) arrangement. This assures that a second power source is not left on if maintenance functions are necessary.
- EdgeGARD® is UL and CSA Listed for electrical safety and integrity.



The EdgeGARD® Model EGBIV22 Space Saver is a two-foot clean bench for applications where space is at a premium. Only 28" wide overall, it is typically used for IV and nursing stations, satellite pharmacies, intensive care units and other small volume clinical or industrial situations.

Cabinet Construction Enhances Performance, Minimizes Downtime

Baker cabinet designs represent many years of experience in stainless steel fabrication and craftsmanship.

- EdgeGARD® cabinets include a corrosion-resistant Type 304 stainless steel work surface and work area side walls.
- A hinged panel located directly below the high velocity return air slots on the leading edge of the work surface provides easy access for cleaning.
- A ½" lip at the rear of the stainless steel work surface prevents spills from entering the HEPA filter.
- The satin finish work surface diminishes harsh light reflection.
- The 18-gauge cold-rolled steel exterior cabinet is protected with a white baked enamel finish.

Caution

A clean bench is not designed to protect personnel or the environment from potentially harmful agents. The adequacy of this product for the user's personal safety, as with any clean bench, should be determined by an industrial hygienist or safety officer.

Site preparation information, architectural drawings, detailed dimensions and purchase specifications are available.

Options and Accessories

For convenience, most options, accessories and modifications are factory installed and should be specified when ordering. Commonly requested options are listed below. For detailed information on accessories and modifications, contact The Baker Company.

- Adjustable leg risers (for work surface height of 36" to 38")
- Service petcocks (in right or left side wall)
- Stainless steel IV bar (removable)
- Plastic storage bins (below work surface)
- Casters (optional)*
- Additional duplex outlet
- Isolated/Microbalanced blower/motor (for lowest vibration)
- Germicidal UV light—(optional)*
- Seismic restraints

To Order

For ordering information, terms and conditions of sale, contact The Baker Company or visit the Baker Web site at www.bakerco.com for the name of your authorized Baker Company representative.

**Not UL Listed with this option.*

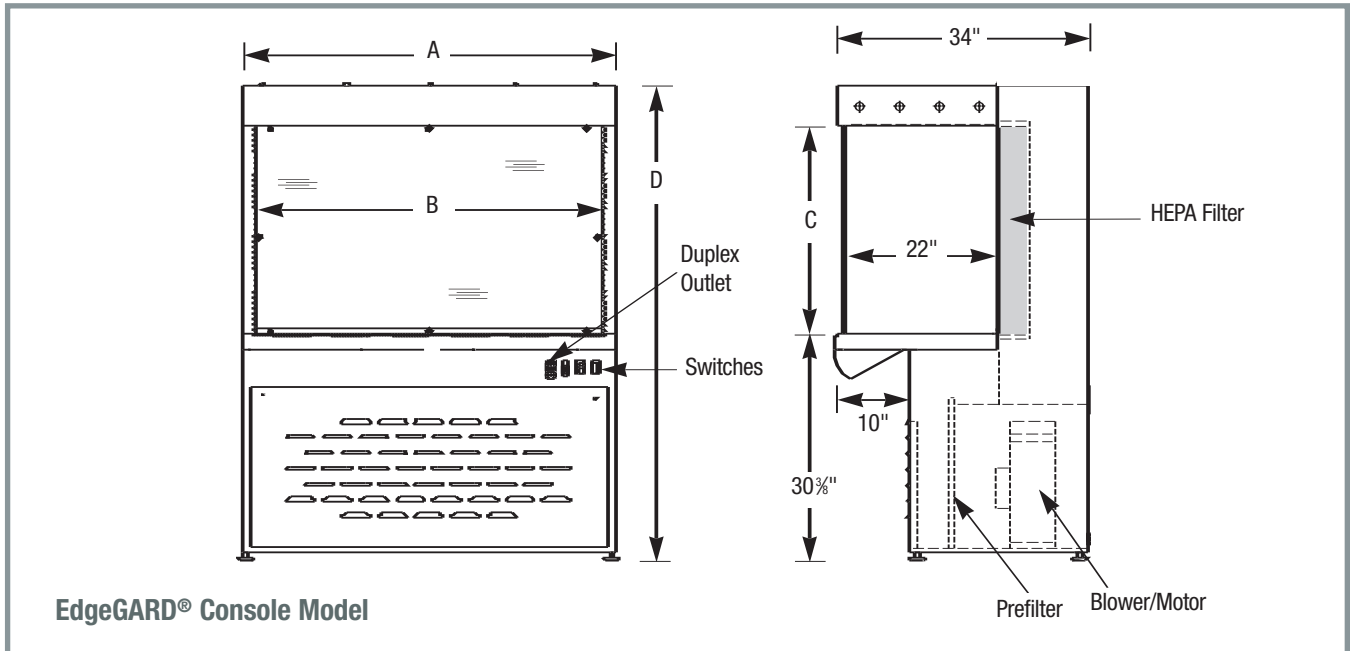

EdgeGARD® Clean Bench

Site Preparation

Console Model Numbers:

EG3252, EG4252, EG4320, EG5252,
EG6252, EG6320, EG8252

Space Saver Model Number:

EGBIV22

Cabinet Type:

Laminar Flow Clean Bench

Filtration System

- Supply filter, zero-probed HEPA filter, 99.99% efficient on all particles 0.3 micron by DOP test.
- Prefilter, washable Scottfoam®
- Dust count, leak test and particle count by single particle monitor or cold DOP photometer which conforms to requirements of FS290b and U.S.A.F. T.O. 00-25-203.

Illumination

- Console and bench models, 200 foot-candles at work surface.
- Space-Saver model, 75 foot-candles at work surface.

Console Models

Model No.	Electrical	Amps	Required Breaker	A Exterior Width	B Interior Width	C Interior Height	D Exterior Height*	Net Weight/ Ship Weight	Filter Size
EG3252	115V, AC	11.8	15 amps	38"	34½"	28½"	64"	360/485 lbs	36"x 30"x 6"
EG4252	115V, AC	14.2	20 amps	50"	46½"	28½"	64"	440/590 lbs	48"x 30"x 6"
EG4320	115V, AC	14.2	20 amps	50"	46½"	34½"	70"	460/610 lbs	48"x 36"x 6"
EG5252	115V, AC	15.5	20 amps	62"	58½"	28½"	64"	520/695 lbs	60"x 30"x 6"
EG6252	115V, AC	18.5	jct box	74"	70½"	28½"	64"	680/880 lbs	72"x 30"x 6"
EG6320	115V, AC	18.5	jct box	74"	70½"	34½"	70"	720/920 lbs	72"x 36"x 6"
EG8252	115V, AC	23.4	jct box	98½"	95"	28½"	64"	800/1050 lbs	48"x 30"x 6" (2)

Note: Models EG4252, EG4320 and EG5252 include 11-foot line cord with 3-prong plug (7-foot cord on Model EG3252).

Models EG6252, EG6320 and EG8252 require a hard wire connection to junction box located in the lower inside right hand corner of the cabinet.

*Exterior heights are listed as minimum dimensions, for maximum height add 2 inches.

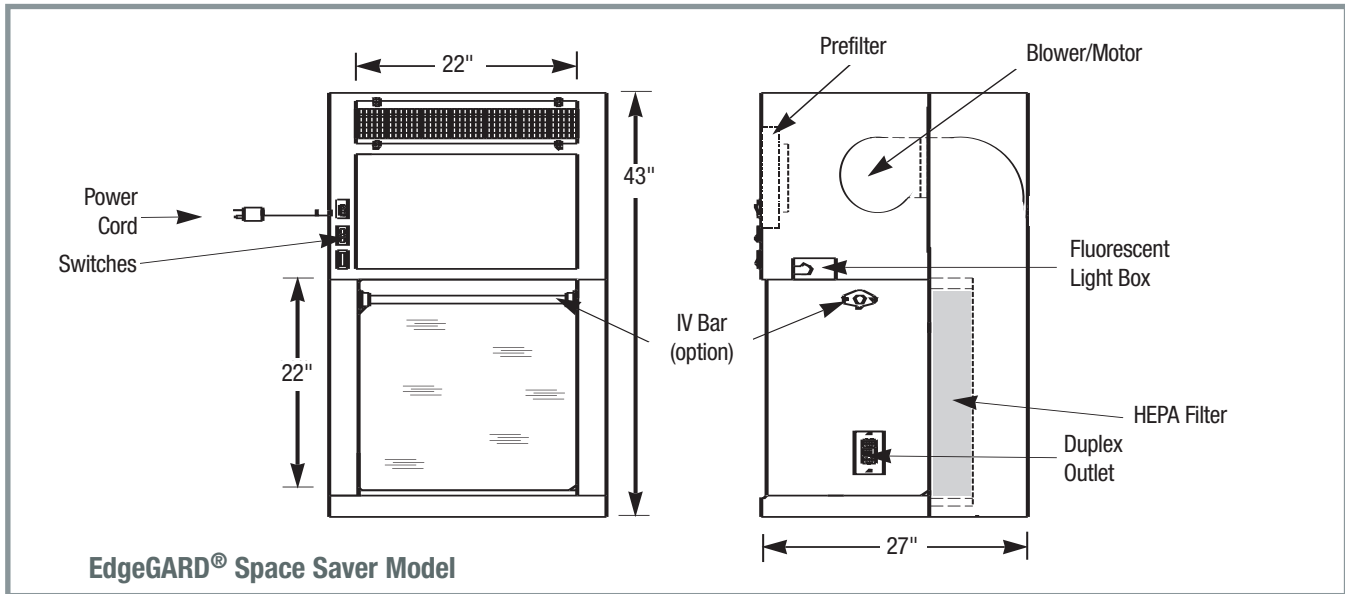

Space Saver Model

Model No.	Electrical	Amps	Required Breaker	Net Weight/ Ship Weight	Filter Size
EGBIV22	115V, AC	11.2	15 amps	200/325 lbs	24"x 24"x 6"

Note: This model includes a 9-foot line cord with 3-prong plug.

13. A removable HEPA filter protective screen shall be provided.
14. Work area shall be provided with externally mounted GFCI protected duplex outlet with circuit breaker.

Purchase Specification EdgeGARD® Horizontal Laminar Flow Clean Bench

1. High velocity return air slots to be located at the leading edges of work surface and side walls. Return air slots protect against backwash of dirty air entering the work area when items are placed within the air stream on the work surface.
2. Unit shall be all steel construction, 18-gauge, cold-rolled steel, with a white baked enamel finish and stainless steel work surface and stainless steel inner work area side walls.
3. Unit shall be provided with permanent split capacitor type motor and special blower which automatically compensates for increasing pressure drop across filter in excess of that which is required by existing standards.
4. Complete unit shall be listed as certified by Canadian Standards Association (CSA) and Underwriters Laboratory (UL) for electrical, fire and personal safety.
5. All joints and seams offering a possible path of contaminated air from outside to the inside of the work area shall be sealed.

6. Framing for the filter seal shall be of rigid angle steel construction and only the filter media shall be exposed to the work area opening, to eliminate picture frame effect.
7. Unit shall have washable reusable Scottfoam® prefilters.
8. Each unit, before shipping, shall have a complete test to assure hood meets all requirements of ISO-14644. A copy of this test will be provided with the unit.
9. The unit manufacturer must be able to provide evidence that this unit has been tested by an independent laboratory or research organization.
10. Speed controller shall automatically compensate for voltage change to maintain constant voltage to motor while allowing for manual adjustments during filter loading.
11. Unit work surface shall feature 1/8" lip at rear to prevent accidental spillage into HEPA filter area.
12. The unit shall have standard HEPA filters for a protection effectiveness of 99.99% when filtering particles of 0.3 micron size.

Warranty

The Baker Company, Inc., expressly represents and warrants all goods (a) to be as specified (and described) in The Baker Company catalogs and literature, and (b) to be free under normal use, service and testing (all as described in The Baker Company catalogs and literature) from defects in material and workmanship for a period of thirty-six months from the invoice date.

The exclusive remedy for any breach or violation of this warranty is as follows: The Baker Company, Inc., will F.O.B. Sanford, Maine, furnish without charge repairs to or replacement of the parts or equipment which proved defective in material or workmanship. No claim may be made for any incidental or consequential damages.

THIS WARRANTY IS EXPRESSLY IN LIEU OF ALL OTHER WARRANTIES, EXPRESSED OR IMPLIED, INCLUDING ANY IMPLIED WARRANTY OF MERCHANTABILITY OR FITNESS FOR A PARTICULAR PURPOSE UNLESS OTHERWISE AGREED IN WRITING SIGNED BY THE BAKER COMPANY. (THE BAKER COMPANY SHALL NOT BE RESPONSIBLE FOR ANY IMPROPER USE, INSTALLATION, SERVICE OR TESTING OF THE GOODS.)

THE BAKER COMPANY

P.O. Drawer E, Sanford, Maine 04073 (207) 324-8773 1-800-992-2537 FAX (207) 324-3869 www.bakerco.com

©2006 The Baker Company