

SterilGARD®

ENERGY EFFICIENT ENGINEERED

Class II, Type A2 Biological Safety Cabinet, Vertical Flow



The better choice
for an optimum balance
of energy efficiency
with performance.

THE BAKER COMPANY



Meets NSF
Standards



Underwriter
Laboratories Listed



UniPressure™
Prewflow Plenum

INTRODUCING
THE BAKER COMPANY
STERILGARD® e3 BIOLOGICAL SAFETY CABINETS



Make the world a better place.

- Multiple energy-saving features equal significant ongoing cost savings
- Continuously safe work environment with self-adjusting motor technology
- Quietest operation available
- Most comfortable with lowest noise and reduced heat generation
- Enhanced productivity with ReadySAFE™ mode
- Extended filter life means less user downtime and waste disposal
- Easier, faster maintenance
- Industry's most durable and reliable cabinet means lower life cycle costs and years of trouble-free operation

SterilGARD



ENERGY EFFICIENT ENGINEERED

The SterilGARD® e3 biological safety cabinet from The Baker Company offers a revolutionary airflow management system with proven containment technology that saves energy, increases productivity and improves comfort.

StediFLOW™ – High-efficiency airflow control system

- Uses less energy without sacrificing performance or safety
- Produces less heat
- Operates more quietly with less vibration
- Motor self-adjusts for continuously safe operation of the class II biosafety cabinet
- Extends filter life, reducing the waste stream in the environment

By redesigning the blower/motor, we've created a more efficient, less demanding and quieter airflow system.



**ReadySAFE™ mode –
Unique bypass armrest allows cabinet
to continue operation with closed
viewscreen**

- Saves energy costs by reducing motor speed by up to 30% when viewscreen is closed
- Maintains containment and clean air conditions to NSF 49 biological challenge criteria at all times
- Increases productivity by allowing user to have instantly safe working conditions upon opening the viewscreen
- Reduces noise level in laboratory environment when in ReadySAFE mode

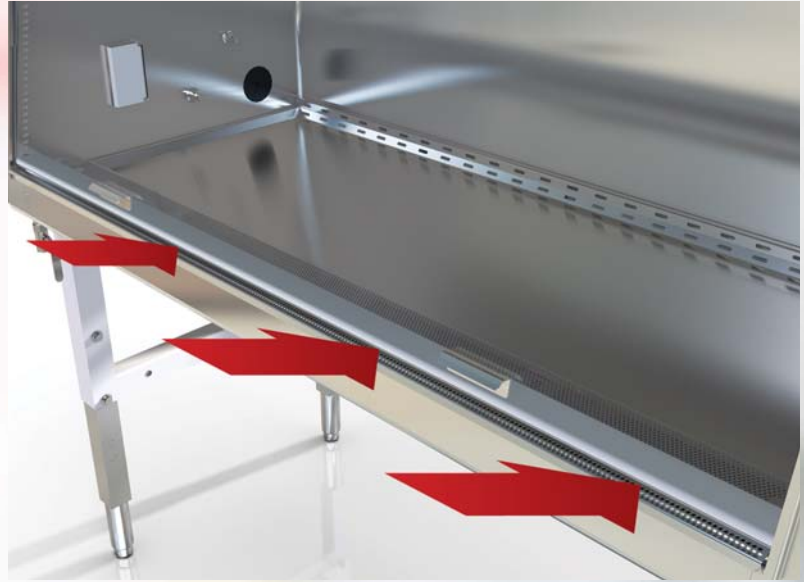

ReadySAFE mode – Unique bypass armrest allows cabinet to continue operation with closed viewscreen

The SterilGARD e3 is the only cabinet in the industry that offers an idle mode, Baker's exclusive ReadySAFE, that is instantly safe upon resuming standard operation. The versatile mode can be used during meetings, lunch breaks and overnights to maintain safe conditions, create a quieter work environment, and save energy.

Industry's most durable and
reliable cabinet
means lower life cycle costs
and years of
trouble-free operation.

Welcome to a new experience in biosafety cabinets.

SAFETY – always our top priority, safety is assured through a variety of features, including an audible/visual sash alarm system and an exclusive cable port to keep cables and tubing out of the way for proper viewscreen closure

ENERGY EFFICIENCY – from the motor controller to the lighting, new patent-pending innovations provide significant annual cost savings while maintaining superior performance

CONTAINMENT – maximum protection is achieved through six technologies working in concert: our exclusive momentum air curtain, high velocity return air slots, aerodynamically designed airfoil, optimized downflow and exhaust filter, and unique air bypass armrest

COMFORT – with eight thoughtful features, from the viewscreen to the work environment and ergonomic design, this cabinet will leave you feeling as good at the end of the day as when you started

EASE OF USE – packed with convenient features and the largest, unobstructed, usable work area in the industry, there's plenty of room for lab equipment and less hassle when changing filters and managing controls

CLEANING – an exceptionally reliable membrane-sealed control panel, and a one-piece work surface/air intake grille featuring radiused, coved corners instead of seams, allows for easy and effective cleaning

SERVICE AND CERTIFICATION – with an innovative electronic controller that provides diagnostic LEDs, detachable side panels, front-loading filters, and a reinforced overall panel design, maintenance is quicker and easier

The SterilGARD e3 cabinet
is the most exciting
development in
biological safety cabinets
in years.

It's what you expect from
The Baker Company.

Industry-leading technologies provide superior protection and maximum efficiency.

StediFLOW™ VFD Motor Controller Automatically Achieves Optimum Performance

Baker's new StediFLOW VFD (variable frequency drive) motor controller uses less energy, reduces heat output and operates more quietly. VFD is state-of-the-art technology in HVAC systems for performance and energy savings. The SterilGARD e3 cabinet can automatically handle an increase in pressure drop of more than 250% across the filter without reducing total air delivery more than 10%. There is no need for manual speed control.

- Maintains precise airflow.
- Reduces amperage required by 40–60% relative to the cabinet's size (4-foot, 5-foot and 6-foot), as compared with traditional cabinets.
- Automatically compensates for normal power line variations, air disruptions and filter loading.
- Constant air volume reduces risk of performance degradation, which can compromise personnel and product protection.
- ReadySAFE operating mode saves energy, maintains protection, and reduces noise levels.

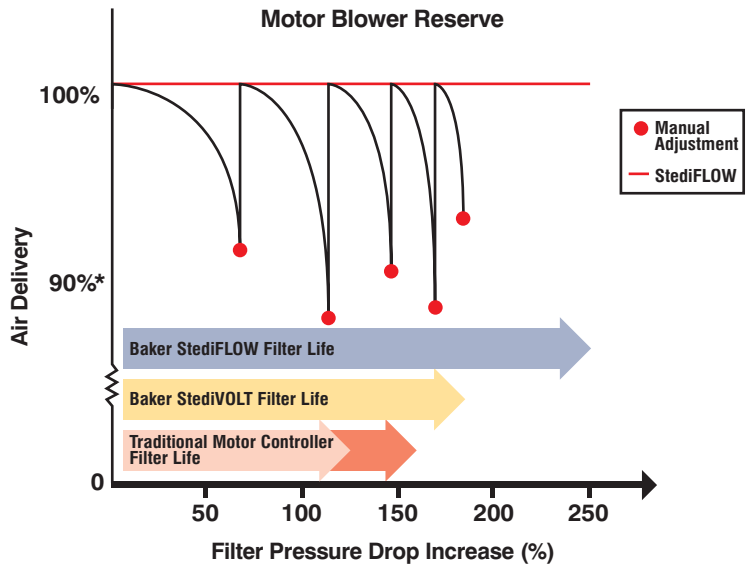

*Manual adjustment may occur above or below 90%.

Electrical Cost Savings

MODEL	KW PER DAY	COST PER DAY	COST PER YEAR	SAVINGS PER YEAR
SG403A	20.40	\$1.82	\$664.30	\$456.25
SG403A-HE	6.53	\$0.57	\$208.05	
SG603A	30.60	\$2.72	\$992.80	\$744.60
SG603A-HE	7.78	\$0.68	\$248.20	

Heat Rejection Savings

MODEL	BTU PER DAY	BTU PER YEAR	DIFFERENCE	SAVINGS PER YEAR
SG403A	69,720	25.45x10 ⁶	60,205/day	\$572.86
SG403A-HE	9,520	3.475x10 ⁶		
SG603A	104,592	38.18x10 ⁶	78,032/day	\$742.49
SG603A-HE	26,560	9.694x10 ⁶		

NOTE:

Based on U.S. Department of Energy national average cost of 9¢ per kilowatt-hour (<http://www.eia.doe.gov/fuelectric.html>)

Based on 8-hour Working Mode, 16-hour ReadySAFE Mode

For more details on calculations, contact The Baker Company.

Innovative UniPressure™ Preflow Plenum Design Optimizes Efficiency

The SterilGARD e3 biological safety cabinet incorporates Baker's exclusive UniPressure Preflow Plenum high-performance airflow system that saves energy and extends filter life by loading filters evenly.

- Creates negative pressure surrounding the positive-pressure plenum to ensure containment; any possible gasket leaks are contained under negative pressure and returned to the HEPA filters.
- Apportions and distributes air across, then through, the HEPA supply filter, improving downflow uniformity, reducing noise and increasing reserve blower/motor capacity.

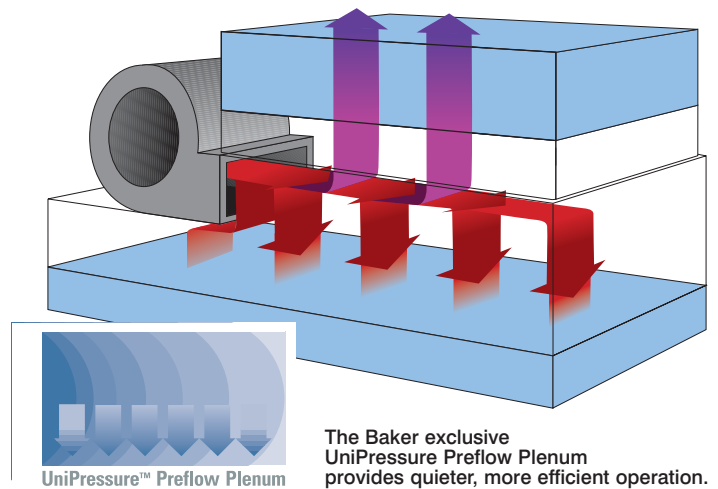

When we make a Baker cabinet, each component is rigorously tested for durability and quality.

- Telescoping filter mount provides direct seal of HEPA filters to plenum, and simplifies filter replacement.
- Closed-cell neoprene gasket forms airtight seal around filter periphery. Force is applied to full perimeter of filter rather than point force.
- Internal damper simplifies airflow balance and cabinet sealing for decontamination.

Blower/Motor System Extends Filter Life

Baker's optimum blower/motor design ensures performance and extends filter life an additional 30% over our previous cabinets—the longest life in the industry—with a range of over 10 years. (High levels of background particulates may shorten HEPA filter life.)

- Provides consistent volume of air despite increases in resistance due to filter loading, resulting in extremely long filter life.
- Extended filter life minimizes filter replacement and decontamination costs, reduces use of toxic fumigants, and produces less waste in the environment.
- Filter does not need to be changed until blower/motor system cannot deliver adequate air volume to maintain nominal setpoint of ± 5 fpm.
- Requires no manual adjustment over filter's life. All filter reserve is automatic.

Momentum Air Curtain Increases Protection

The SterilGARD e3 cabinet employs a unique momentum air curtain that offers an added measure of containment and protection exclusive to the Baker design.

- Creates strong air barrier, or momentum air curtain, at front of cabinet, increasing protective capabilities for both products and personnel.
- Strategic position of stainless steel diffuser just below supply filter creates faster airflow at front of work area. Airflow over center of work surface is gentle at nominal 50 fpm.
- Resulting air curtain combines with high-velocity return air slots, aerodynamically contoured front-opening surfaces, and optimum air intake velocity to minimize turbulence and prevent migration of airborne contaminants into or out of work area.

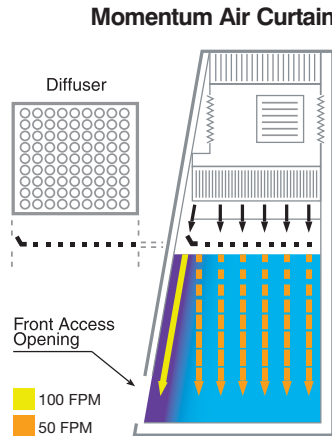

High-velocity return air slots maximize protection.

High-Velocity Return Air Slots Capture Unfiltered Air

Containment and cleanliness are achieved with precise control of airflow volumes and velocities. A unique feature in the Baker cabinet design, the high-velocity return air slots have been proven to maximize the biological safety cabinet's protective capabilities.

- Prevent contaminants from migrating up behind the viewscreen or around the side wall and escaping into operator's environment.
- Prevent room air from migrating down behind the viewscreen or around the side wall and contaminating work area.



Patent-pending, NSF-approved cable port on right allows cables and/or tubing to exit cabinet side walls rather than front work area, eliminating obstructions, hazards, and interference with proper viewscreen closure.

Negative-Pressure Double-Wall Plenums Enhance Safety

Baker's unique all-metal, double-wall design of the SterilGARD e3 cabinet creates base, side and back wall plenums that capture and contain contaminated air under negative pressure. Any plenum that contains biologically contaminated air under positive pressure is completely surrounded by negative-pressure areas.

- Ensure integrity of plumbing connection, electrical outlet seals, and Baker's patent-pending cable ports.
- Prevent contaminated air from escaping into laboratory environment in event of damage to cabinet walls.

Balanced Airflow and Exhaust Ensure Uniformity

The SterilGARD e3 cabinet features a unique airflow design that delivers unidirectional downflow air over the work area for maximum containment and protection.

1. Filtered air descends from top to bottom of the work area in a unidirectional flow. Near the back of the work surface, the air current divides—a portion of the downflow air is pulled through the back wall grille and the remainder is pulled through the front grille.
2. Simultaneously, room air is pulled through the front opening and into the front grille. It does not enter the work area.
3. All air combines under the work surface and is pulled under negative pressure through the back and side double walls of the cabinet into the blower/motor, which blows it into the positive-pressure preflow plenum.
4. From the positive-pressure plenum, approximately 30% of the air exits the system through the exhaust filter. The remaining 70% passes through the downflow filter and re-enters the work area as particulate-free air.

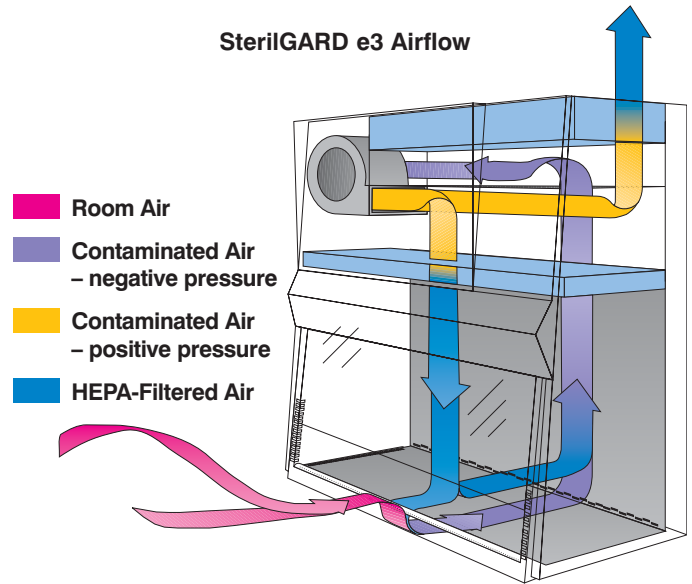

Exclusive 10°
slanted
viewscreen—
less glare,
work easier
to reach.

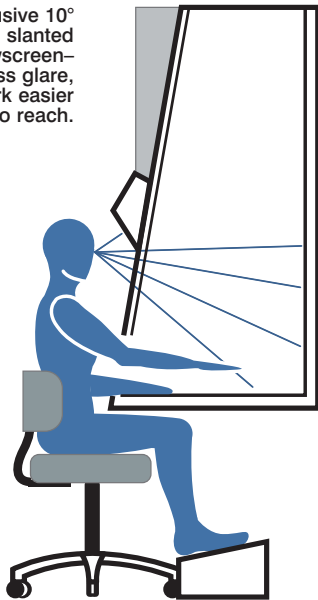

Slanted Viewscreen Offers Comfort and Safety

The SterilGARD e3 cabinet has a slanted sliding viewscreen that minimizes glare and makes the cabinet easier to use and more comfortable to work in. A counterbalancing feature allows the user to open and close the viewscreen effortlessly.

- Allows operator more comfortable head and elbow position, reducing fatigue.
 - Provides safe, highly visible and easily accessible work area for wide range of procedures.
 - Rugged, easy-to-use counterweight allows easy opening and closing of viewscreen.
 - Maximum opening simplifies equipment and instrument loading and unloading.
 - Integrated alarm audibly and visually warns of improper viewscreen position.
- Viewscreen-level mute button silences alarm for 5 minutes when viewscreen is raised for cleaning, loading or unloading.
 - Laminated safety-glass construction.
 - Stainless steel edge protector prevents chipping and cracking.

Efficient Lighting Illuminates Better while Saving Energy

Benefits of the SterilGARD e3 cabinet include new fluorescent lamps and electronic ballasts that save energy, improve visibility and enhance productivity.

- New cool-white lights use less energy, produce less heat and provide better color fidelity.
- Electronic ballasts reduce fluorescent lamp flicker, minimizing eyestrain and improving productivity.
- Lamps provide an average of greater than 125 foot-candles of illumination at work surface.
- The standard bulb is outside of the containment area and is easy to replace by the cabinet operator—no service call or special ordering is required.

Working Environment Offers Optimum Ease of Use and Comfort

In addition to the viewscreen and lighting features, a variety of convenient enhancements make the SterilGARD e3 one of the most comfortable working environments.



The microprocessor-based control board with membrane control panel simplifies operation.

- Unobstructed, usable work area is the largest in the industry and can accommodate more lab equipment because of the rear grille being parallel to the straight back wall.
- Reduced front grille depth moves work surface closer to front for better arm position, which helps minimize back pain.
- Low-profile, unitized drain pan beneath work surface allows more leg room.
- Air bypass padded armrest provides support and comfort.
- Eye-level control panel offers greater visibility and easier access.
- Nonglare work surface reduces eyestrain.
- Available stand with telescoping legs allows for an adjustable work surface height.
- Offset petcocks eliminate “knuckling” by providing easier access and reducing injury.
- Convenient built-in timers for lights and outlets come standard, minimizing risks and reducing energy consumption.
- Consolidated electrical controls on panel behind hinged light canopy offer unique access outside containment area.

Supply and Exhaust Filters Perform Optimally

Because filters remove microorganisms and airborne particulates (e.g., aerosols) from the air, the quality, performance and useful life of downflow and exhaust filters are critical biosafety considerations.

- Leak-free performance is ensured through scan tests conducted at the factory prior to shipping and is confirmed at the cabinet’s initial certification.
- Closed-cell neoprene gasket provides airtight seal between filter assembly and metal plenum.
- VFD motor system and large-sized filters yield the longest filter life in the industry.

Exclusive Designs Simplify Certification and Testing

Several SterilGARD e3 design features help simplify certification and maintenance, reducing downtime and improving life cycle costs.

- Telescoping plenum assembly puts downflow and exhaust HEPA filters within easy reach from the front of the cabinet, and allows filters to be clamped directly to plenum against closed-cell neoprene gasket.
- Exhaust and downflow filters easily inserted and removed from front, helpful if cabinet is connected to exhaust duct or room has low ceiling.
- Internal damper regulates balance between exhaust and downflow to maintain proper air circulation ratios. Damper can be adjusted by certifier to compensate for changing resistance of downflow and exhaust filters as they load with particles.

Craftsmanship Ensures Quality

Baker cabinet designs represent many years of experience in stainless steel fabrication and craftsmanship. Design considerations such as wide radius corners, aerodynamically shaped surfaces and nonglare satin - finish interiors combine to improve comfort, simplify cleaning and maintain proper containment.

- Work surface and walls are one-piece, corrosion-resistant, stainless steel with smooth radius corners for easy cleaning. White powder finish protects cold-rolled steel cabinet exterior.
- Work surface and supports are easily removed to facilitate cleaning drain pan.
- Stainless steel air diffuser/filter protector shields downflow filter in work area and provides uniform downflow and momentum air curtain.
- Protective grille under negative-pressure side walls prevents wipes and other paper materials from being inadvertently drawn into blower system, eliminating costly servicing, decontamination and downtime.
- Entire cabinet is airtight. Each component is welded, gasketed or assembled with hermetically sealed joints. Each cabinet is bubble-tested under pressure—at the factory prior to shipping—to ensure integrity of seals.

Electrical System Provides Safeguards

The SterilGARD e3 electrical system is designed for safety and convenience.

- GFCI-protected duplex outlets with drip-proof covers are provided on each side wall.
- Independent self-resetting circuit breaker protects control circuits from possible overloads.
- Sealed connectors and fittings provide reliable containment for cabinet penetrations.
- Single power cord and plug as sole disconnect device ensure a second power source is not unintentionally left connected when performing service.
- UL-listed for electrical safety and integrity.
- Viewscreen position and UV interlock are monitored by reliable noncontact proximity switches.

Petcocks, Valves and Plumbing Connections Offer Convenience

Plumbing and drainage connections are strategically placed for convenience and proper air management.

- One petcock and one plugged penetration are standard on right wall.
- Petcocks and penetrations are offset to prevent “knuckling” and provide for easier access and use.
- External plumbing connections are made to the bottom or back of cabinet rather than sides, allowing installation next to walls or furniture, saving valuable lab space.
- Stainless steel ball valve provides safe and effective drainage of drain pan.

Options and Accessories

Most options, accessories and modifications are factory-installed and should be specified when ordering. Common options are listed below. For additional information, contact The Baker Company.

- Viewscreen sash opening: 10" for 4-foot and 6-foot models, 12" for 5-foot model (8" is standard)
- UV germicidal lamp
- Stainless steel IV bar
- Additional petcock (specify label and location)
- Plumb to back
- Plastic storage bins
- Ergonomic adjustable footrest
- FlexAIR® Exhaust Connection
- Type A2 exhaust kit, canopy connection
 - Mass airflow monitor
 - Decon seal box
- Reinforced work surface
- Seismic restraints
- Stand with telescoping legs
- Stand with casters
- Remote-controlled petcocks
- Electric hydraulic lift
- Auxiliary wiring package (for monitoring blower switch status)
- ULPA filters

Optional Ultraviolet Lamp with Safety Interlock

An optional ultraviolet germicidal lamp assists in contamination control.

- The lamp’s safety interlock ensures that UV illumination occurs only when the viewscreen is fully closed.
- For added safety, the UV light switch and cabinet lighting cannot be turned on simultaneously.
- Lamp runs on a timer and is used on an as-needed basis to conserve energy.

Ordering

For ordering information, terms and conditions of sale, contact The Baker Company or visit the Baker Web site at bakerc.com for the name of your authorized Baker Company representative.

Class II, Type A2 Applications

The SterilGARD e3 biological safety cabinet is designed for many applications involving agents of low and moderate risk. Appropriate applications include, but are not limited to, sterile product preparation and biological experimentation.

- When exhausted to the room, the SterilGARD e3 cabinet is classified as a Class II, Type A2 cabinet.
- Properly vented to the outdoors through a facility exhaust system, the SterilGARD e3 cabinet exceeds minimum standards for a Class II, Type A2 cabinet (formerly B3).

TYPE A2	EXHAUSTED TO ROOM	EXHAUSTED TO UNTREATED FACILITY EXHAUST SYSTEM	EXHAUSTED TO TREATED FACILITY EXHAUST SYSTEM
Protection from Particulates	Protects personnel, product and the environment	Protects personnel, product and the environment	Protects personnel, product and the environment
Protection from Gases and Vapors	No	Protects personnel	Protects personnel and the environment

SterilGARD e3 Containment and Protection

SterilGARD e3 (SG503A-HE)

(Specific measurements for the SG403A-HE and the SG603A-HE are given in red.)

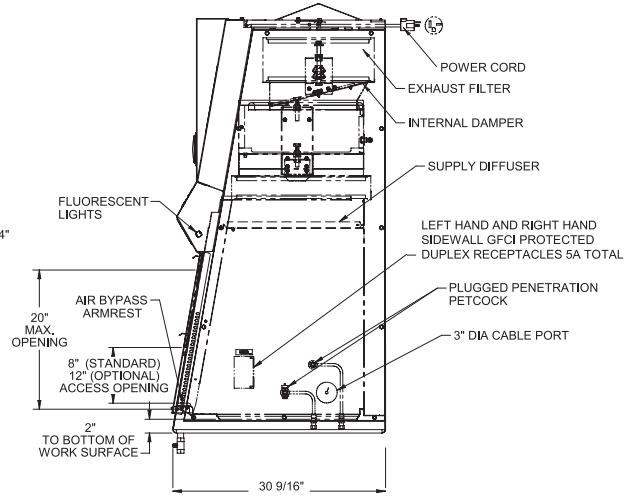
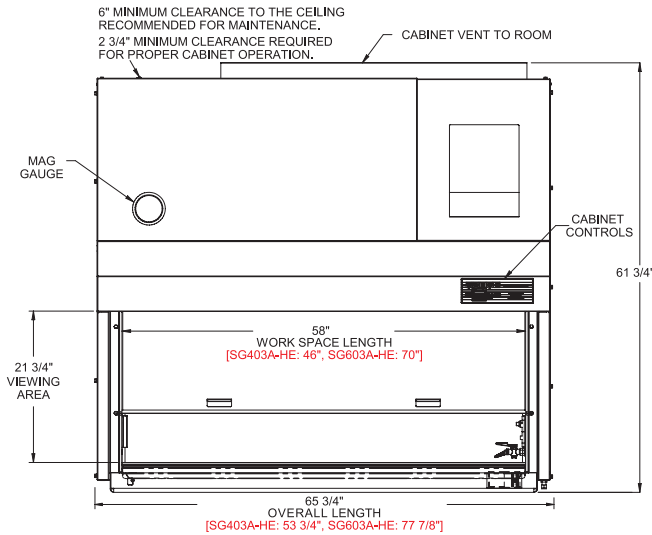

Telescoping Stand (optional)

An optional stand with telescoping legs allows the cabinet to be adjusted to a wide range of standard work surface heights.

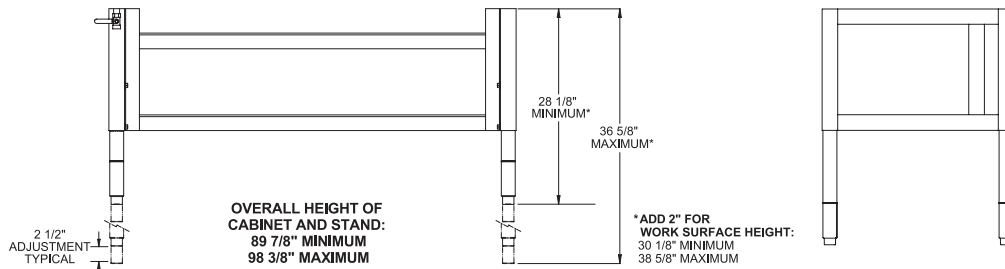

SITE PREPARATION ELECTRICAL SYSTEM

- 115 VAC, 20A, 60Hz, 1 phase
- One 14' power cord with 20-amp plug, NEMA 5-20P
- Unit is cULus-Listed as certified for electrical, fire and personal safety
- Two ground-fault circuit interrupter-protected interior duplex receptacles at 5.0 total amps protected by a self-resetting circuit breaker

EXHAUST OPTIONS

The SterilGARD e3 is designed for Type A2 installations. For added convenience, the cabinet design includes several innovative features that offer flexibility.

Downflow and exhaust HEPA filters can be inserted and removed from the front of the cabinet, allowing filter replacement without removing exhaust connections or moving the cabinet.

CANOPY EXHAUST CONNECTION (CEC)

Laboratories that share common exhaust systems typically experience changes in airflow that can compromise cabinet operation. Such problems include (a) too much room air being drawn through the cabinet, causing potential product contamination, or (b) too little air drawn through the cabinet, compromising personnel and/or product protection.

Located between the cabinet exhaust HEPA filter and the building exhaust system, the canopy exhaust air gap maintains Type A2 cabinet performance over a range of exhaust flow rates (see chart). Type A2 cabinet performance is also maintained in the event of total building exhaust failure. The SterilGARD e3 canopy exhaust connection (CEC) incorporates the following features:

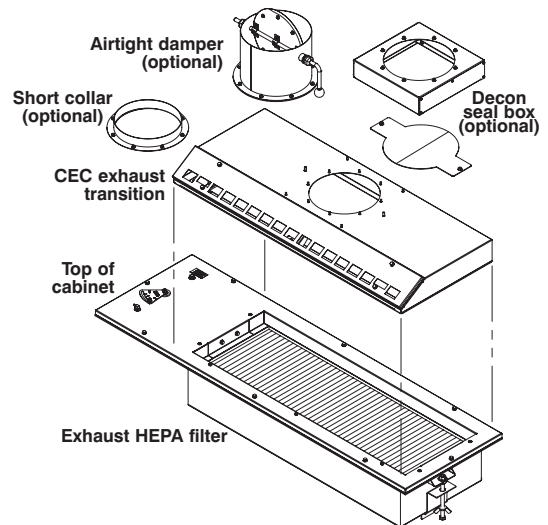

- Designed for quick, efficient installation to protect cabinet from performance degradation caused by in-house exhaust system fluctuation.
- Unique combination design consists of an exhaust transition (ET) that creates the desired air gap in the overall connection.
- 10" diameter exhaust connection collar.

FILTRATION SYSTEM

- Exhaust and downflow HEPA filters are both 99.99% efficient.
- Optional ULPA filters are 99.999% efficient.

Detailed Specifications



SG603A-HE

SG503A-HE

SG403A-HE

MODEL NO.	SIZE	OPENING MAX.	ELECTRICAL REQUIRES 20 AMP OUTLET	INTERIOR DIMENSIONS USABLE WORKSPACE	EXTERIOR DIMENSIONS	CABINET WEIGHT* (lbs)	SHIPPING WEIGHT** (lbs)
SG403A-HE	4'	20"	115V, AC 20A, 60 Hz	46" W x 20 ³ / ₁₆ " F-B x 27 ⁷ / ₁₆ " H	53 ³ / ₄ " W x 30 ⁹ / ₁₆ " F-B x 61 ³ / ₄ " H	668	798
SG503A-HE	5'	20"	115V, AC 20A, 60 Hz	58" W x 19 ⁵ / ₈ " F-B x 27 ⁷ / ₁₆ " H	65 ³ / ₄ " W x 30 ⁹ / ₁₆ " F-B x 61 ³ / ₄ " H	756	906
SG603A-HE	6'	20"	115V, AC 20A, 60 Hz	70" W x 19 ⁵ / ₈ " F-B x 27 ⁷ / ₁₆ " H	77 ⁷ / ₈ " W x 30 ⁹ / ₁₆ " F-B x 61 ³ / ₄ " H	830	1000

* Includes optional stand

** Includes packaging and optional stand

MODEL NO.	SASH HEIGHT	NOISE (dBa)	OPERATING AMPERAGE*	READYSAFE AMPERAGE	POWER CONSUMPTION** (Watts)	HEAT GENERATION† (BTU/hr)
SG403A-HE	8"	60	3.6	1.6	432	1474
	10"	61	4.0	1.7	480	1638
SG503A-HE	8"	65	4.0	1.7	480	1638
	12"	67	6.7	1.9	804	2743
SG603A-HE	8"	65	5.5	2.0	660	2252
	10"	66	6.7	2.0	804	2743

* Amperage for new cabinet with clean filters

** Power consumption at 120V

† Calculated maximum based on operating amperage

MODEL NO.* WITH CANOPY EXHAUST CONNECTION (CEC)	EXHAUST REQUIREMENTS		
	SASH HEIGHT	EXHAUST FLOW RATE	EXHAUST STATIC PRESSURE**
SG403A-HE	8"	345 CFM	-0.25" WC
	10"	430 CFM	-0.30" WC
SG503A-HE	8"	430 CFM	-0.35" WC
	12"	645 CFM	-0.40" WC
SG603A-HE	8"	520 CFM	-0.40" WC
	10"	650 CFM	-0.50" WC

* Cabinets previously classified as Class II, Type A/B3 are now classified as Class II, Type A2. These cabinets can be exhausted to the room (previous Type A classification) or connected to a facility exhaust system (previous Type B3 classification) via a "canopy" connection (previously referred to as a "thimble"). NSF 49 (2002) specifies the "canopy" connection only because vented exhaust through a "hard" connection, though technically possible, may not meet NSF criteria. Consult The Baker Company or your laboratory safety officer for details.

** With the optional airtight damper, add 0.1" WC (25 Pa) to the above static pressure requirements.

SterilGARD, Class II, Type A2 Biological Safety Cabinet, Vertical Flow

PERFORMANCE

1. Manufacturer shall provide a certified copy of the personnel, product and cross-contamination (biological) tests, equivalent to or more demanding than as specified in NSF International Standard #49, performed on the unit selected from the corresponding statistical sample. Tests may be witnessed by a representative of the purchaser.
2. Cabinet shall have momentum air curtain downflow velocity profile, i.e., a higher velocity of downflow behind the viewscreen relative to downflow velocity over the work surface for added personnel and product protection.
3. High velocity return air slots shall be located at each end of the front access opening. These slots help to prevent contaminated air from being drawn into the work area along the edges of the side wall and from escaping the work area to the ambient environment.
4. High velocity return air slots shall also be located behind the viewscreen on the top edge for enhanced containment and product protection.
5. Cabinet shall be capable of automatically handling a 250% minimum increase in filter loading without reducing total air delivery by more than 10%. Test data to verify these capabilities shall be available upon request.
6. Intake velocity through the front access opening shall be minimum of 100 FPM. Standard openings are 8" and 10" for the 403A-HE and 603A-HE; standard openings for the 503A-HE are 8" and 12".
7. Unit must be listed by NSF International as meeting Standard #49.
8. Each unit, before shipping, shall have a complete physical test to assure cabinet meets Class II requirements. A copy of this test will be provided with the operator's manual shipped with the unit.
9. The unit shall have standard HEPA filters for a protection effectiveness of 99.99% on 0.3 micron size particles by DOP test. Filters shall be serviceable from front of cabinet.
10. Cabinet interior (work area) construction: one-piece, 16-gauge, Type 304 stainless steel, with a smooth, $7/16$ " radius between rear and side walls, and easily cleanable, radiused corners on the work surface tray.
11. Work area side walls and rear wall to be one-piece construction. A straight back wall shall be provided to maximize work area and easily accommodate laboratory equipment.
12. Cabinet shall be double-wall construction with negative-pressure airflow between the walls, from drain pan to top, surrounding the sides and back of work area and cable port.
13. Bottom of access opening shall be aerodynamic airflow design directing airflow into the front grille to improve access opening containment capability and bypass armrest.
14. Cabinet shall have a unitized drain pan with $7/16$ " radius on all sides and a fully removable work surface and work surface supports to facilitate cleaning.
15. Cabinet shall be equipped with a stainless steel ball valve to allow safe and effective draining of spills.
16. Stainless steel air diffuser and filter protector provided in work area and on top of cabinet.
17. Externally adjustable internal damper provided to compensate for changing resistance of exhaust and supply filters during certification.
18. One petcock and one plugged penetration are provided as standard on the right side wall. Left side wall is prepunched for optional/additional plumbing connections.
19. All external plumbing connections to the petcocks shall be made through the bottom or back of the cabinet and not the sides, allowing zero clearance between the unit and the building walls or equipment to its right and left.
20. The unit is available with an optional stand, which includes telescoping legs that allow the work surface height to be set from $30^{1/8}$ " to $38^{5/8}$ ".
21. Viewscreen guide design shall be a counterweighted pulley system allowing effortless movement up and down.

CONSTRUCTION

1. The vertical sliding viewscreen shall be slanted at an angle of 10° from vertical, capable of moving to a fully closed position during shutdown periods.
2. Viewscreen shall be constructed of $1/4$ " laminated safety plate glass, with a maximum opening of 20" for equipment loading.
3. All biologically contaminated ducts, plenums and work area side walls shall be permanent metal construction and maintained under negative pressure or enclosed within a negative-pressure zone.
4. Interior work area shall be $27^{7/16}$ " high.
5. Cabinet shall have The Baker Company's exclusive UniPressure Preflow Plenum, designed to provide more uniform airflow to the supply filter.
6. Supply and exhaust filters shall be front loading.
7. A telescoping plenum assembly shall be provided to allow the filters to be directly clamped to the plenum against a closed-cell neoprene gasket. Plenum applies force to full perimeter of filters, rather than point force.
8. Unit shall have an audible alarm and a flashing LED to indicate when the sliding viewscreen is in an unsafe position. An alarm mute switch shall be provided on the front-mounted cabinet control panel to allow the operator to mute the alarm tone for brief adjustments. The alarm shall automatically reactivate after five minutes if the viewscreen remains in an unsafe position.
9. Cabinet exterior construction: seal panels and dress panels of 16-gauge cold-rolled steel, powder coated finish, painted PermaWhite™.

ELECTRICAL

1. Complete unit shall be listed as certified by Underwriters Laboratory (cULus) for electrical, fire and personal safety.
2. Cabinet shall have a microprocessor-based control system with an easy-to-clean membrane control panel mounted on the front of the cabinet facing down towards the user when sitting at the unit.
3. Cabinet shall have adjustable timers for fluorescent lights, outlets and optional UV lights. Timers operate in 15-minute intervals.
4. Work area shall be provided with two GFCI-protected duplex outlets with drip-proof covers and shall be protected by a self-resetting circuit breaker.
5. A single 14-foot power cord and plug (NEMA 5-20P) shall be provided for electrical power source.
6. The unit shall have optional UV light with a shutoff safety feature when the viewscreen is raised.
7. The unit shall have electronic ballasts for UV and fluorescent lighting to provide longer life and lower heat output.
8. Cabinet shall have an externally mounted fluorescent light fixture with solid state ballasts producing 125 foot-candles illumination at work surface.

Caution

A Class II, Type A2 biological safety cabinet is suitable for work with agents in the absence of volatile toxic chemicals and volatile radionuclides per NSF 49.

With proper ventilation to the outside, a Class II, Type A2 biological safety cabinet is suitable for work with agents assigned to biosafety levels 1, 2 or 3, treated with minute quantities of volatile toxic chemicals and trace amounts of radionuclides required as an adjunct to microbiological studies, that will not interfere with the work when recirculated in the downflow air (as stated in National Sanitation Foundation International Standard #49).

Note: The adequacy of this containment cabinet for the user's personal safety, as with any containment cabinet, should be determined by an industrial hygienist or safety officer. Site preparation information, architectural drawings, detailed dimensions and purchase specifications are available.

Warranty

The Baker Company, Inc., expressly represents and warrants all goods (a) to be as specified (and described) in The Baker Company catalogs and literature, and (b) to be free under normal use, service and testing (all as described in The Baker Company catalogs and literature) from defects in material and workmanship for a period of thirty-six months from the invoice date.

The exclusive remedy for any breach or violation of this warranty is as follows: The Baker Company, Inc., will F.O.B. Sanford, Maine, furnish without charge repairs to or replacement of the parts or equipment that proved defective in material or workmanship. No claim may be made for any incidental or consequential damages.

THIS WARRANTY IS EXPRESSLY IN LIEU OF ALL OTHER WARRANTIES, EXPRESSED OR IMPLIED, INCLUDING ANY IMPLIED WARRANTY OF MERCHANTABILITY OR FITNESS FOR A PARTICULAR PURPOSE UNLESS OTHERWISE AGREED IN WRITING SIGNED BY THE BAKER COMPANY. (THE BAKER COMPANY SHALL NOT BE RESPONSIBLE FOR ANY IMPROPER USE, INSTALLATION, SERVICE OR TESTING OF THE GOODS.)

THE BAKER COMPANY

P.O. Drawer E, Sanford, ME 04073 • (207) 324-8773 • (800) 992-2537 • Fax: (207) 324-3869 • www.bakerco.com

© 2009 The Baker Company. All rights reserved.



Creating
Immaculate
Atmospheres

FlexAIR® Exhaust Connection

Innovation in BSC venting saves energy and provides safer BSC performance

Baker's new FlexAIR Exhaust Connection combines the safety of a traditional canopy (thimble) exhaust connection with the lower exhaust flows of a traditional hard exhaust connection. Now, energy savings can be realized without sacrificing safety cabinet performance.

How It Works: Baker's new FlexAIR works by having dynamic closure panels. The front panel automatically opens in the event of exhaust system slowdown or failure, allowing the cabinet to maintain Class II, Type A2 BSC performance. With FlexAIR, only the minimum amount of air necessary to achieve cabinet exhaust containment is used, compared to traditional canopy exhaust connections that exhaust an additional 20 percent conditioned air from the room. FlexAIR reduces exhaust air volume for significant energy and cost savings.

FlexAIR system includes an alarm feature to let workers know when the house exhaust system has slowed down or stopped. This may be important if your work includes the use of volatile organic solvents, gasses, or vapors (which are not captured by HEPA filters).

MODEL NO.	EXHAUST REDUCTION	ANNUAL ENERGY SAVINGS*	EXPECTED PAYBACK	AVAILABILITY
<i>Savings versus traditional canopy, when purchased with a new BSC (8" sash)</i>				
SG403A-HE	50 CFM	\$300	<1 YEAR	NOW
SG503A-HE/SG603A-HE	60 CFM	\$360	<1 YEAR	NOW
<i>Savings versus traditional canopy, for field replacement (8" sash)</i>				
SG403A	35 CFM	\$210	5-6 YEARS	CALL
SG603A	45 CFM	\$270	4-5 YEARS	CALL

* Assumes \$6/CFM/YEAR conditioned air cost

TO ORDER: Call 1-800-992-2537 to speak with a customer service representative or visit our web site at www.bakerco.com to order online. For field replacement installations, please have the serial number of your cabinet handy so we can provide you with the correct parts.

THE BAKER COMPANY



THE BAKER COMPANY

SterilGARD®III Advance° Model 303 Sets the Industry's Highest Standard for Compact Size, Comfort, Performance and Safety.

SterilGARD®III 303 Advance°

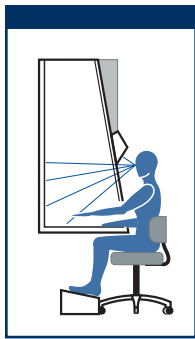

*Exclusive
10° slanted
viewscreen—
less glare,
work easier
to reach.*



SterilGARD®III Advance° 303 Class II, Type A2* Biological Safety Cabinet, Vertical Flow

In the laboratory environment, safety is everything. Now, with the introduction of SterilGARD®III Advance° 303, The Baker Company offers a compact ergonomic design, combined with a unique airflow management system and proven containment technology, to improve comfort, increase productivity and reduce the cost of ownership.

SterilGARD®III Advance° 303 is a collective design, representing an esteemed reputation for performance, reliability and craftsmanship associated with The Baker Company worldwide for nearly 50 years.

SterilGARD®III Advance° 303 starts with a simple idea: a better angle. From your first experience with the

10° slanted viewscreen, you'll appreciate how easy the SterilGARD®III Advance° 303 is to use. Your work is easy to reach. There's more functional room inside. Eye-level controls are easy to see. There is less glare. As you work, your head and neck, arms and elbows, remain in the most natural position, less tiring than before.

Along the streamlined viewscreen, concealed behind the attractive front panels, you'll find another Baker exclusive—UniPressure™ Preflow Plenum, an elegantly simple yet effective air management system that puts more uniform air pressure on the supply filter for better vertical flow across the work surface. A simple idea, to be sure, but by moving the blower/motor to a horizontal orientation from vertical, we've created a more efficient, less demanding and quieter airflow system.

And years later, if it comes time for maintenance, your certifier will find the cabinet easy to seal and easy to decontaminate. Our new direct-to-plenum filter mounting technique puts the HEPA filter on a telescoping frame, within easy reach, easy to change.

SterilGARD®III Advance° 303 is the most exciting development in biological safety cabinets in years. Consider the angle. Learn more about SterilGARD®III Advance° 303. It's what you would expect from The Baker Company.

**Properly vented to the outdoors through a facility exhaust system, SterilGARD®III Advance° 303 meets or exceeds minimum standards for a Class II, Type A2 (formerly B3) cabinet.*



CONFORMS TO UL STD 61010A
CERTIFIED TO CAN/CSA 22.2
STD NO. 1010.1



UniPressure™
Preflow
Plenum



Design and Performance Features

SterilGARD®III Advance° 303 incorporates UniPressure™ Prewlow, the Baker exclusive high performance airflow system which provides optimum protection from particulates, together with extended filter life and reduced cost of ownership.

- The unique UniPressure™ Prewlow Plenum design apports and distributes air *across*, then *through* the HEPA supply filter, improving downflow uniformity, extending useful filter life and reducing noise.
- The UniPressure™ Prewlow filter housing creates negative pressure surrounding the positive pressure plenum to improve containment; any possible gasket leaks are contained under negative pressure.
- An innovative telescoping filter mount provides a direct seal of the filter to the UniPressure™ Prewlow Plenum, and simplifies filter replacement.
- Supply and exhaust HEPA filters are rated at 99.99% minimum efficiency in capturing 0.3 micrometer particulates.
- The Baker exclusive *momentum air curtain* contains particulates within the work area and inhibits migration of room air into the work area.
- High velocity return air slots located along the side walls of the work area and along the top of the viewscreen maximize the biological safety cabinet protective capabilities by preventing the escape of particulates, ensuring that no unfiltered air enters the work area, and preventing gases, vapors or particulates from migrating up behind the viewscreen and escaping into the operator's environment.
- Aerodynamically designed airfoil at the front opening facilitates the flow of room air into the front grille, ensuring that no room air flows into the work area.

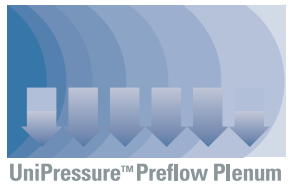

SterilGARD® III Advance° 303

Advantages

Comfortable and Easy to Work In

Ergonomic Features and Benefits

- The slanted viewscreen is sloped 10° to create the most natural head and elbow position when working, minimizing arm extension required to reach the work surface, and reducing glare.
- The eye-level control panel is positioned to face down toward the user for greater visibility and easier access.
- Reduced front grille depth and a slim profile lower plenum combine to move the work surface closer to the front and your lap for better arm position.
- Our new UniPressure™ Prewlow Plenum delivers quieter, more efficient performance.
- One petcock supplied standard; one additional petcock available, optional.
- An armrest (optional) across the cabinet front improves support and comfort.
- An optional stand with telescoping legs allows the work surface height to be adjusted from 30½" to 38½".

More Space for Your Work, Your Equipment and You

- SterilGARD® III Advance° 303 offers a large, unobstructed work area.
- Depth of the front grille is minimized to bring the work closer to the user.
- Rear grille is parallel to the back wall to increase useable work space.
- A straight back wall maximizes available work area and accommodates lab equipment and apparatus commonly used in the biological safety cabinet.

Easy to Clean and Maintain

- A unitized, unobstructed drain pan with radius corners facilitates cleaning.
- Streamlined design of the sliding viewscreen simplifies sealing prior to total cabinet decontamination.
- The telescoping UniPressure™ Prewlow Plenum simplifies filter changing.
- All electrical control components are consolidated on a panel behind the hinged canopy for singular access outside the containment area.
- The innovative horizontal blower/motor assembly is easily removed and replaced.

The SterilGARD®III Advance° 303 design is based on extensive anthropometric data, and was developed by The Baker Company in cooperation with ergonomics researchers at a leading university.

- The PLC™ Programmable Logic Controller with touchpad membrane control panel simplifies operation; controls are more reliable, easy to use and easy to clean.
- An audible/visual sash alarm system warns of unsafe viewscreen opening.
- A large, easy-to-read magnehelic

- gauge confirms cabinet operation.
- Detachable side panels offer greater flexibility for plumbing considerations; the reinforced panel design reduces the number of fasteners and simplifies removal and replacement.
- The front panels are lighter and easier to remove for filter changing.

Class II, Type A2 Applications

The SterilGARD® III Advance° 303 biological safety cabinet is designed for sterile product preparation and biological experimentation involving agents of low and moderate risk.

- The SterilGARD® III Advance° 303 is classified a Class II, Type A2 cabinet.
- SterilGARD® III Advance° 303 exceeds minimum standards for a Class II, Type A2 cabinet (formerly B3).

Momentum Air Curtain Increases Protection Without Restricting Access

SterilGARD® III Advance° 303 employs a unique *momentum air curtain* which offers an added measure of containment and protection exclusive to the Baker design.

- This unique airflow design creates a more impenetrable air barrier or *momentum air curtain* at the front of the cabinet, increasing the cabinet's protective capabilities.
- The strategic position of the stainless steel diffuser just below the supply filter creates a faster

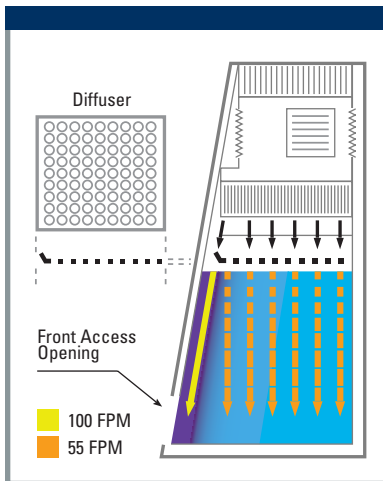

Momentum Air Curtain

SterilGARD® III Advance° 303 Design Features

- 1 Slanted viewscreen sloped 10° for the most comfortable head and elbow position when working; minimizes arm extension required to reach the work surface.
- 2 Low profile, unitized drain pan beneath the work surface allows best arm position above the user's lap.
- 3 Eye-level controls face down toward the user, for greater visibility and easier access.
- 4 PLC (programmable logic controller) with touchpad membrane control panel simplifies operation.
- 5 Optional stand with telescoping legs allow the work surface to be adjusted from 30 1/2" to 38 1/2".
- 6 Audible/visual sash alarm with timer and mute switch encourages safe operation.
- 7 A large, easy-to-read magnehelic gauge confirms cabinet operation.
- 8 High velocity return air slots maximize protective capabilities.
- 9 HEPA supply and exhaust filters, 99.99% minimum efficiency for 0.3 micrometer particulates.
- 10 StediVOLT® voltage regulator automatically adjusts for low and high voltage situations to maintain proper airflow.
- 11 Energy-saving fluorescent lighting with solid-state ballasts reduce flicker, minimize heat output, improve eye comfort, and extend lamp life by as much as 50%.
- 12 Non-glare work surface improves comfort.
- 13 One ground-fault interrupt (GFI) duplex outlet with self-resetting circuit breaker for user safety; trip light warns circuit has been disconnected because of ground fault error.
- 14 Straight back wall easily accommodates lab apparatus and instrumentation.



SterilGARD® III Advance° 303

airflow of a nominal 100 FPM at the front of the work zone.

- Airflow over the center of the work surface is relatively slower at a nominal 55 FPM.
- The resulting air curtain, high velocity return air slots, aerodynamically contoured front opening surfaces, and

optimum air intake velocity, combine to minimize turbulence and prevent migration of airborne contaminants into or out of the work area.

Balanced Airflow and Exhaust Assure Uniformity

The SterilGARD®III Advance° 303 features superb airflow characteristics which deliver unidirectional, downflow air over the work area for maximum containment and protection.

- Filtered air descends from top to bottom of the work area in a unidirectional flow. Near the center of the work surface, the air current divides; a portion of the downflow air is pulled through the back wall grille and the remainder is pulled through the front perforated grille.

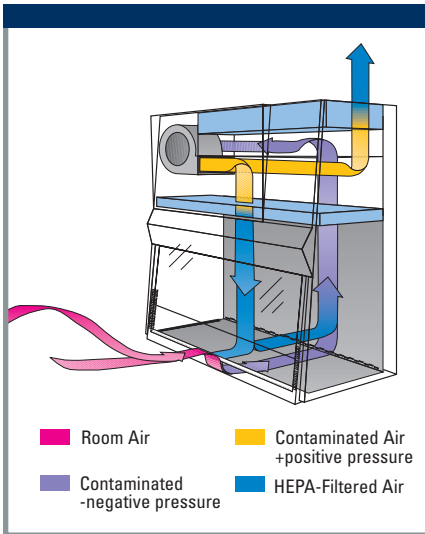

SterilGARD®III Advance° 303 Airflow

- Simultaneously, room air is pulled through the front access opening and into the front perforated grille. It does not enter the work area. The calculated average intake air setpoint velocity at the front access opening is 105 FPM.

SterilGARD®III Advance° 303 Containment and Protection

	Type A2	Type A2	Type A2
	Exhaust to room	Exhausted to untreated facility exhaust system	Exhausted to treated facility exhaust system
Protection From Particulates	Protects personnel, product and the environment	Protects personnel, product and the environment	Protects personnel, product and the environment
Protection From Gases and Vapors		Protects personnel	Protects personnel and the environment

When installed as a Type A2 cabinet with direct exhaust to the facility exhaust system by a canopy or hard connection, the SterilGARD®III Advance° 303 provides particulate protection, plus additional protection of personnel from minute amounts of vapors and gases. If exhausted to a facility exhaust system specially treated with activated charcoal, scrubbing or catalytic conversion, protection from exhausted vapors and gases is extended to the environment.

- All air is combined under the work surface. From this point, contaminated air is pulled under negative pressure through a plenum up the rear and sides of the cabinet into the blower/motor, which blows it into a positive pressure plenum.
- From the positive pressure plenum, approximately 30% of the air exits the system through the exhaust filter. The remaining 70% passes through the supply filter and re-enters the work area as particulate-free air.

High Velocity Return Air Slots Capture Unfiltered Air

Containment and cleanliness are accomplished with precise control of airflow volumes and velocities. A unique feature in the Baker cabinet design, the high velocity return air slots, have been proven to maximize the biological safety cabinet protective capabilities.

- High velocity return air slots are located along the side walls of the work area and along the top of the viewscreen.
- Air is drawn into these slots at approximately 1,000 FPM, preventing the escape of particulates and ensuring that no unfiltered air enters the work area.
- High velocity return air slots located along the top of the sliding viewscreen prevent gases, vapors or particulates from migrating up behind the viewscreen and escaping into the operator's environment, and prevent room air from migrating down behind the viewscreen and contaminating the work area.

Baker PLC Programmable Logic Controller

The SterilGARD® III is operated by a robust, microprocessor-based programmable logic controller (PLC) designed to manage and monitor internal performance with options for user configuration.

- The controller protects SterilGARD® III systems from the effects of momentary voltage interruptions, electrical noise and vibration common to laboratory environments.
- UV lamp timing functions are easily programmed for on/off operation.
- Status indicators simplify troubleshooting.
- Data acquisition can be downloaded to a remote monitoring or data logging system through an RS232 data port (optional RS485).
- Large, ergonomically accessible touchpad icons are easy to identify and operate.
- The control panel is positioned to face down towards the user for greater visibility and easy access.
- The sash alarm timer and audible alarm mute button override the alarm for 5 minutes when the sash is raised for cleaning, loading or unloading.
- A large, easy-to-read magnehelic gauge provides a continuous visual confirmation of cabinet air pressure.

Negative Pressure Double-Wall Plenums Enhance Safety

The all-metal, double wall design in SterilGARD® III Advance° 303 creates base, side and rear wall plenums which capture and contain contaminated air under negative pressure. This unique Baker design feature prevents contaminated air from escaping into the

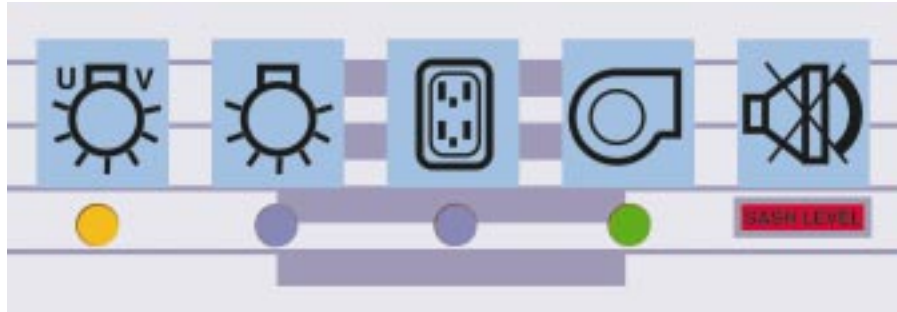

The PLC™ Programmable Logic Controller is accessed through a moisture-proof touchpad membrane control panel that is easy to clean and operate.

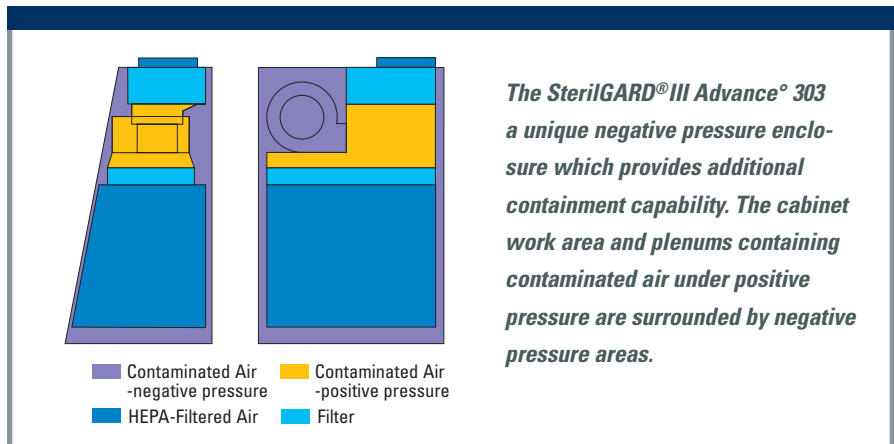

The SterilGARD® III Advance° 303 a unique negative pressure enclosure which provides additional containment capability. The cabinet work area and plenums containing contaminated air under positive pressure are surrounded by negative pressure areas.

laboratory environment in the event of a puncture or leak in the cabinet.

- Any plenum which contains biologically contaminated air under positive pressure is completely surrounded by negative pressure areas.
- Because of negative pressure in the base, side and rear walls, the work area is surrounded by negative pressure.

High Visibility Viewscreen With Sash Alarm

SterilGARD® III Advance° 303 has a streamlined 10° slanted sliding viewscreen which makes the cabinet easier to use and more comfortable to work in.

- The operator's head, neck, arms and elbows remain in the most natural position to improve comfort and reduce fatigue.
- All work is within reach; the angled viewscreen design provides a safe, highly visible and easily accessible work area for a range of procedures.

- The slanted viewscreen minimizes glare.
- The vertical lift viewscreen is constructed of ¼" safety plate glass.
- The sash has an 8" working opening with an average calculated air intake velocity of 100-110 FPM.
- A maximum viewscreen sash opening of 17¾" simplifies equipment and instrument loading and unloading.
- An integrated viewscreen sash alarm includes an audible and visual indicator to warn of improper sash opening above the 8" opening. The alarm is disabled when the sash is fully closed.
- The viewscreen sash alarm timer and audible alarm mute button override the alarm for 5 minutes when the sash is raised for cleaning, loading or unloading.

UniPressure™ Prewlow Advanced Filter Plenum Design

The SterilGARD® III Advance° 303 incorporates UniPressure™ Prewlow, a revolutionary air delivery system which offers significant benefits through unique integration of supply and exhaust HEPA filter assemblies,

a telescoping filter mount, an all-steel plenum with external damper, and a new horizontal blower/motor configuration.

- Located between the HEPA filters, the supply air plenum is configured to provide more uniform air flow to the supply filter, while reducing noise and increasing reserve motor capacity.

- The all-steel telescoping plenum clamps directly to the HEPA filters. Force is applied to the full perimeter of the filters rather than point force.

- A closed-cell neoprene gasket forms an airtight seal around the filter periphery.

- The horizontal blower assembly creates more uniform air direction to the supply HEPA filter, thereby reducing noise, increasing motor reserve and extending filter life.

- A new external damper simplifies airflow balance and cabinet sealing for decontamination, and protects the exhaust HEPA filter.

Supply and Exhaust Filter Performance

Because filters remove microorganisms and airborne particulates (generally called aerosols) from the air, the quality, performance and useful life of supply and exhaust filters are critical considerations in the biosafety environment.

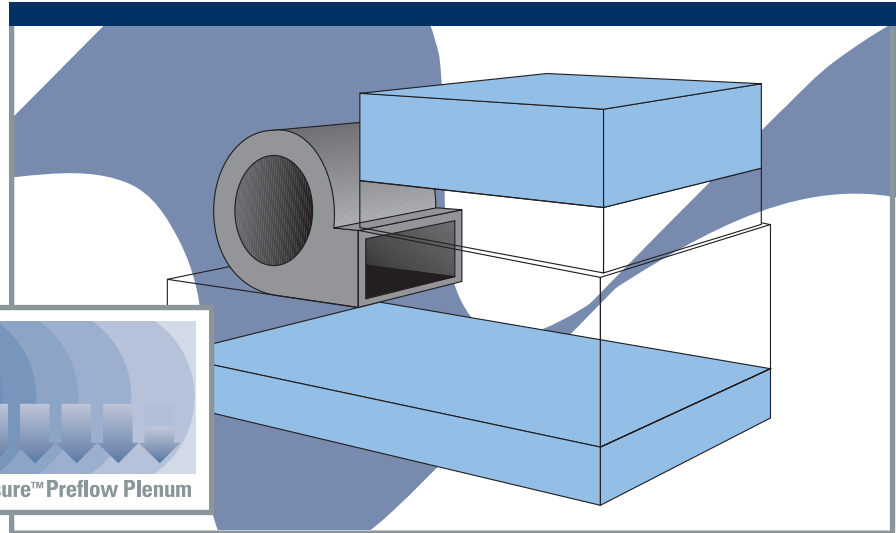

The Baker exclusive UniPressure™ Prewlow Plenum provides quieter, more efficient operation.

- Each filter in each Baker cabinet is scan tested for leaks and tested for overall efficiency by the manufacturer, then individually scan tested by Baker after installation to assure leak-free performance.

- Minimum filter efficiency is 99.99% for particulates 0.3 micrometers, increased efficiency for particulates greater and smaller than 0.3 micrometers.

- Both exhaust and supply HEPA filters can be inserted and removed from the front of the cabinet. This time-saving feature is useful if the cabinet is connected to an exhaust duct.

- A closed-cell neoprene gasket provides an airtight seal between the filter assembly and the metal plenum.

Blower/Motor System Helps Extend Filter Life

Baker has selected an optimum blower/motor combination to assure performance and to extend filter life to an average of 7 to 10 years, the longest life in the industry. The Baker blower/motor provides a constant

volume of air despite increases in resistance due to filter loading, resulting in extremely long filter life as verified by simulated filter loading tests.

Extended filter life minimizes filter replacement and decontamination costs, and diminishes the hazard to personnel by reducing the frequency of opening the contaminated areas of the cabinet. The more filter resistance the blower/motor system can overcome, the longer between filter changes.

- As particulates fill the filter media, resistance to airflow increases.

- The Baker blower/motor is a direct drive permanent split capacitor motor, designed to deliver the maximum amount of filter life for each cabinet.

- The blower/motor automatically compensates for filter loading up to 60% above the initial pressure drop across the filter. Beyond that point, the blower/motor has a manual speed control which can be turned up to achieve even longer filter life.

- The filter need not be changed until the blower/motor system cannot deliver adequate air volume to maintain the nominal setpoint, ± 5 FPM.

Easier On-Site Certification and Testing

Several SterilGARD® III Advance° 303 design features combine to simplify certification and maintenance for qualified service personnel, thus reducing downtime and improving life cycle costs.

- A telescoping plenum assembly puts the supply and exhaust HEPA filters within easy reach, and allows the filters to be clamped directly to the plenum against the closed-cell neoprene gasket.
- Both exhaust and supply filters can be easily inserted and removed from the front of the cabinet. This time-saving feature is useful if the cabinet is connected to an exhaust duct or if the room has a low ceiling.
- An external adjustable damper allows the certifier to compensate for changing resistance of supply and exhaust filters; the damper regulates the balance between intake and downflow so that the proper air circulation ratios are maintained.
- A manual speed controller allows the certifier to increase blower/motor speed to compensate for filter loading.

StediVOLT® Motor Speed Controller Maintains Optimum Performance

The Baker exclusive StediVOLT® motor speed controller reduces the risk of performance degradation and possible product loss due to line voltage fluctuations.

- StediVOLT® minimizes changes in cabinet performances due to routine voltage fluctuations, as well as voltage changes caused by high-demand, brownout conditions.

Motor Loading Capacity

Model	Pressure Drop Increase	Maximum Increase With Manual Blower Speed Control
SG303, 3-foot	60%	200%

SterilGARD® III Advance° 303 is capable of automatically handling a 60% increase in pressure drop across the filter without reducing total air delivery more than 10%. With the use of the manual speed controller, the SterilGARD® III Advance° 303 can handle up to a 200% increase in pressure drop across the filter.



- StediVOLT® reads incoming voltage, automatically compensates for low and high voltage, and maintains proper blower speed to prevent periods of unbalanced airflow which may contribute to loss of containment or product protection.

Comfortable Lighting Improves Visibility, Reduces Heat

Ergonomic benefits of the SterilGARD® III Advance° 303 include new flicker-free fluorescent lamps and electronic ballasts which provide better visibility, less heat at the face (front) of the cabinet, and improved user comfort.

- Lamps provide more than 100 foot-candle lighting at the work surface.
- Electronic ballasts eliminate fluorescent lamp flicker, minimizing eye strain and improving productivity.
- The warm, natural illumination exhibits better color fidelity.

Optional Ultraviolet Lamp Includes Safety Interlock

An optional ultraviolet germicidal lamp assists in contamination control.

- The UV light interlock assures that UV illumination occurs only when the sash is fully closed.
- For added safety, the UV germicidal light switch and cabinet lighting cannot be turned on simultaneously.
- The UV light can be programmed to shut off after a pre-set time.

Cabinet Construction Enhances Performance, Minimizes Downtime

Baker cabinet designs represent many years of experience in stainless steel fabrication and craftsmanship. Design considerations such as wide radius corners, aerodynamically shaped surfaces and non-glare satin finish interiors combine to improve comfort, simplify cleaning and maintain proper containment.

- SterilGARD® III Advance° 303 includes a corrosion-resistant, 16-gauge, Type 304 stainless steel work surface with smooth radiused corners to permit easy cleaning. The recessed work area retains spills.

Telescoping Stand (Optional)

	Knee Space Height	Work Surface Height	Overall Height
Minimum Setting	28 $\frac{1}{8}$ "	30 $\frac{1}{8}$ "	91 $\frac{1}{4}$ "
Maximum Setting	36 $\frac{5}{8}$ "	38 $\frac{5}{8}$ "	99 $\frac{3}{4}$ "

SterilGARD® III Advance° 303 features an optional stand with telescoping legs to permit multiple work surface heights. This unique stand allows the cabinet to be adjusted to standard work surface heights ranging from 30 $\frac{1}{8}$ " to 38 $\frac{5}{8}$ ".

- The satin finish work surface diminishes harsh light reflection.
- A protective grille, located under the work surface at the bottom of the rear and side return air plenums, prevents wipes and other paper materials from being inadvertently drawn into the blower system. This eliminates costly decontamination and downtime to extract materials from the blower.
- Work area side walls and rear wall are one-piece, 16-gauge stainless steel construction with $\frac{1}{8}$ " radiused corners for cleaning convenience.
- The position of the stainless steel air diffuser/filter protector located below the supply filter in the work area creates the *momentum air curtain* at the front opening and provides filter protection.
- The 16-gauge, cold-rolled steel exterior cabinet is protected with a white baked enamel finish.
- The entire cabinet is airtight. Each component is welded, gasketed or assembled with hermetically sealed joints. Each cabinet is bubble tested under pressure to ensure the integrity of these seals.
- To facilitate cleaning the drain pan, the work surface and supports are easily removed and the drain pan has large $\frac{1}{8}$ " radii on all sides.

Electrical System Offers Safety and Convenience

The SterilGARD® III Advance° 303 electrical system is designed for safety and convenience. GFI duplex outlet, rear wall, center, is provided to accommodate most commonly used laboratory instruments and equipment.

- Outlet is provided with a drip-proof cover and self-resetting circuit breaker.
- The internal work area outlet is on a separate circuit from the cabinet lights and blower/motor so that an overload caused by research equipment will not affect cabinet function.
- Hermetically sealed bulkhead connectors are used to provide reliable containment protection for electrical connectors which penetrate the cabinet contaminated areas.
- For safety reasons, the SterilGARD® III Advance° 303 cabinet utilizes a single power cord and plug arrangement. This assures that a second power source is not left on if maintenance functions are necessary.
- The SterilGARD® III Advance° 303 is ETL Listed for electrical safety and integrity.

Functional Utilities With Petcocks, Valves and Plumbing Connections

Plumbing and drainage connections are strategically placed for both convenience and proper air management within the airflow plenums.

- One petcock is located in the right work area side wall. One plugged penetration is provided to accommodate an optional petcock inside the cabinet on the left side wall.
- Petcocks and penetrations are offset, not one on top of the other, for easier access and use.
- External plumbing connections are made to the bottom (or optionally top or back) of the cabinet rather than through its sides. This arrangement allows installation next to building walls or furniture to the right or left of the cabinet, saving valuable lab space.
- A stainless steel ball valve provides safe and effective drainage of the drain pan.

Options and Accessories

For convenience, most options, accessories and modifications are factory installed and should be specified when ordering. Commonly requested options are listed below. For detailed information on accessories and modifications, contact The Baker Company.

- UV germicidal lamp
- Stainless steel IV bar
- Additional petcock (specify label and location)
- Plumb to top
- Plumb to rear
- Plastic storage bins
- Mass Airflow Monitor
- Armrest
- Ergonomic adjustable footrest
- Reinforced work surface
- Seismic restraints
- Optional stand with telescoping legs
- Optional stand with casters

To Order

For ordering information, terms and conditions of sale, contact The Baker Company or visit the Baker Web site at www.bakerco.com for the name of your authorized Baker Company representative.

Caution:

A Class II, Type A2 biological safety cabinet is suitable for work with agents in the absence of volatile toxic chemicals and volatile radionuclides. With proper ventilation to the outside, a Class II, Type A2 biological safety cabinet is suitable for work with agents assigned to biosafety levels 1, 2 or 3, treated with minute quantities of volatile toxic chemicals and trace amounts of radionuclides required as an adjunct to microbiological studies, that will not interfere with the work when recirculated in the downflow air (as stated in National Sanitation Foundation International Standard #49).

Note: The adequacy of this containment cabinet for the user's personal safety, as with any containment cabinet, should be determined by an industrial hygienist or safety officer. Site preparation information, architectural drawings, detailed dimensions and purchase specifications are available.

SG303*



SG603

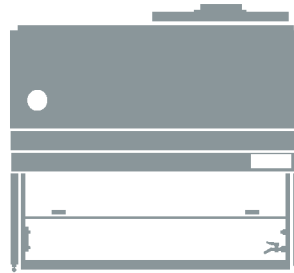

SG403

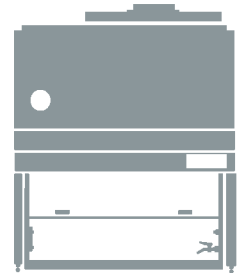

The SterilGARD® III Advance° is also available in 4' and 6' models. For literature and information contact The Baker Company.

Summary Specification

SterilGARD® III Advance° 303 Class II, Type A2 Biological Safety Cabinet, Vertical Flow

Model No.	Size	Opening	Electrical	Amps/ Breaker	BTU	Interior Dimensions	Exterior Dimensions	Net Weight*	Ship Weight
SG303	3'	8" (17¼")	115 VAC	9.0/20	1767	27 ¾"W x 22 ⅞"F-B x 27 ¼"H	35 ⅝"W x 30 ⅞"F-B x 63 ⅛"H	397 lbs	534 lbs

*Net weight SG303 with the optional stand is 457 lbs, with a total shipping weight of 594 lbs.

SG303 is not NSF listed.

Conforms to UL STD 61010A Certified To CAN/CSA 22.2 STD NO. 1010.1



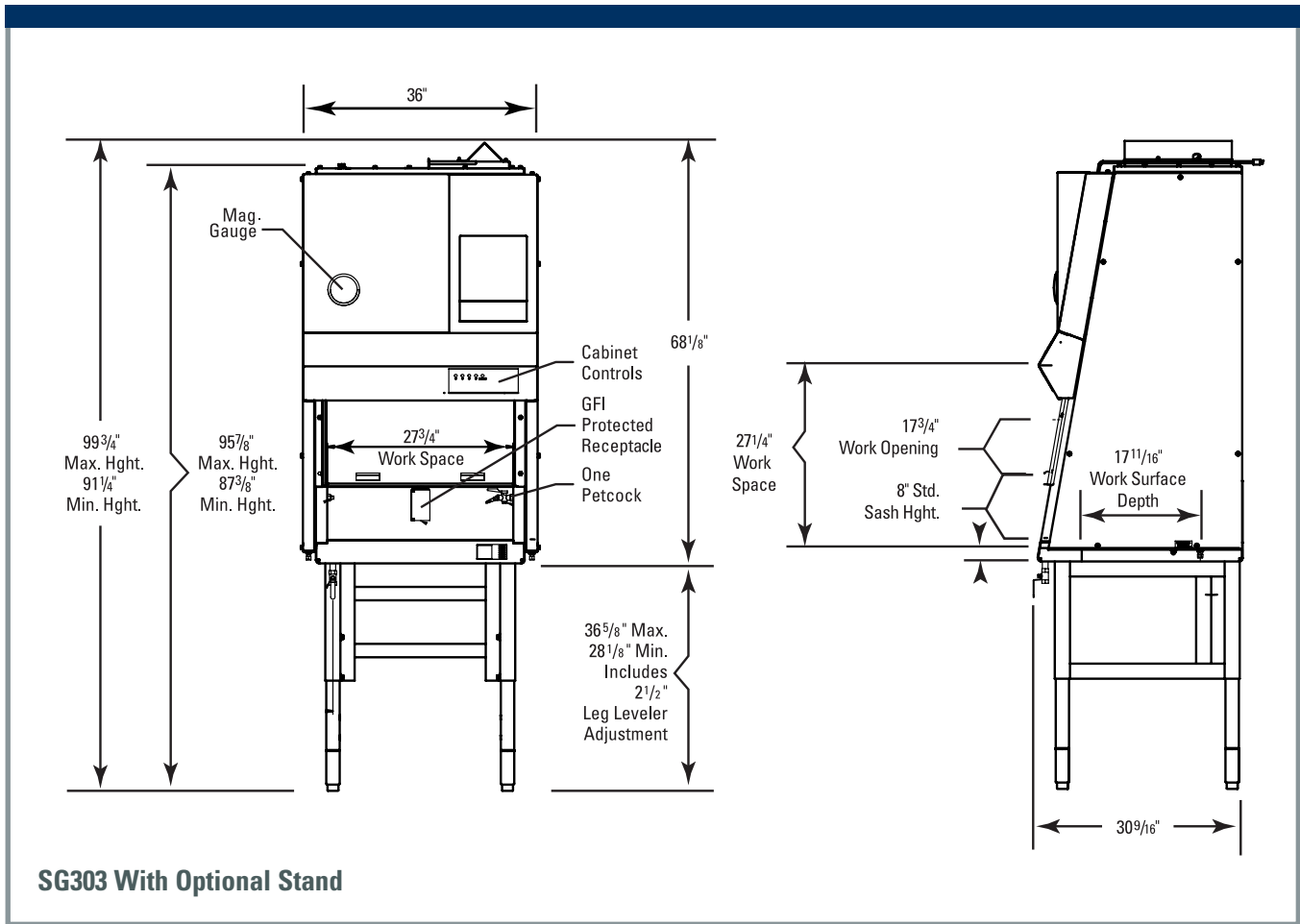

SG303 With Optional Stand

**SterilGARD® III
Advance**

Model Number: SG303, 3'

**NSF Classification:
Class II, Type A2**

**Cabinet Type: Bench
(Stand Optional)**

**Site Preparation
Electrical System**

- 115V-1. Phase, 60 Hz.
- One 16' power cord with 20-amp plug, NEMA 5-20P.

- Unit is ETL Listed as certified for electrical, fire and personal safety.
- One ground-fault interrupt protected interior duplex receptacle at 5.0 amp, controlled by a touch pad switch.

**Exhaust Requirement
SG303**

- For an 8" opening: 162 CFM at .02" to .04" water column suction directly above the exhaust filter before any reductions, elbows or restrictions.

Amperage Chart

Model	Blower/Motor	Lighting Ballast	Duplex Receptacle	Total
SG303	1625 RPM, 3.2 amps	0.41 amps	5.0 amps	9.0 amps

Exhaust Options

The SterilGARD® III Advance° 303 is designed for Type A2 installations. For added convenience, the cabinet design includes several innovative features which offer flexibility.

- The exhaust transition (ET) is easily convertible to a canopy exhaust connection (CEC) by adding a single collar.
- Both supply and exhaust HEPA filters can be inserted and removed from the front of the cabinet, allowing filter replacement without removing exhaust connections.

Canopy Exhaust Connection (CEC)

Laboratories which share common exhaust systems typically experience changes in airflow which can compromise cabinet operation. Such problems include (a) too much room air being drawn through the cabinet, causing potential product contamination, or (b) too little air drawn through the cabinet, compromising personnel protection. Located between the cabinet exhaust HEPA filter and the building exhaust system, the canopy exhaust air gap maintains Type A2 cabinet performance over a range of exhaust flow rates (see chart). Type A2 cabinet performance is also maintained in the event of total building exhaust failure. The SterilGARD® III Advance° 303 canopy exhaust connection (CEC) incorporates the following features:

- Designed for quick, efficient installation to protect cabinet from performance degradation caused by in-house exhaust system fluctuation.

Exhaust Requirements

Cabinet Models	Exhaust Connection	Sash Height	Exhaust Flow Rate (CFM)	Pressure Loss Range	Duct Diameter
Canopy Exhaust Connection					
SG303	CEC303	8"	260-370	0.02-0.08" wc	8"
Exhaust Transition (Hard Connection)*					
SG303	HEC303	8"	162	0.2" wc	8"

**Cabinets previously classified as Class II, Type A/B3 are now classified as Class II, Type A2. These cabinets may be exhausted to the room (previous Type A classification) or connected to a facility exhaust system (previous Type B3 classification) via a "canopy" connection (previously referred to as "thimble"). NSF 49 (2002) specifies the "canopy" connection only because vented exhaust through a "hard" connection, though technically possible, may not meet NSF criteria. Consult Baker or your laboratory safety officer for details.*

- Unique combination design consists of an exhaust transition (ET) plus a special collar which creates the desired air gap in the overall connection.
- Exhaust connection collar is 8" diameter on the CEC303.

Exhaust Transition (ET) for Hard Connection

The exhaust transition (ET) provides a hard connection, or airtight mating of the cabinet to the exhaust duct, in which flow rates for cabinet intake, cabinet exhaust and building exhaust are all equal. The ET303 is designed for the 3' cabinet. The exhaust transition incorporates the following features:

- Rectangular base is easily installed on top of the cabinet over the exhaust filter, requiring only 4 bolts to provide an airtight seal.
- Design enables accurate airflow measurement and filter leak checking through a convenient access panel on the sloping surface.

- An optional airtight damper is available for sealing the cabinet during decontamination.
- Exhaust connection collar is 8" diameter.

Filtration System

- Exhaust and supply filters zero-probed HEPA, both 99.99% efficient on all particles 0.3 micrometers by DOP test.

SterilGARD® III Advance° 303

- 1 Canopy cone with collar
- 2 Exhaust transition
- 3 Exhaust filter
- 4 Exhaust filter access cover

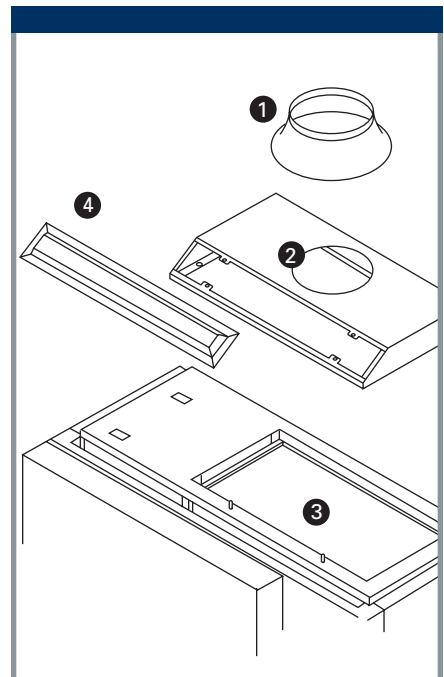

Purchase Specification
SteriGARD® III Advance® Model 303
Class II, Type A2 Biological
Safety Cabinet

1. Manufacturer shall provide a certified copy of the personnel, product and cross-contamination (biological) tests, equivalent to or more demanding than as specified in NSF International Standard #49, performed on the unit selected from the corresponding statistical sample. Tests may be witnessed by a representative of the purchaser.
2. Cabinet shall have *momentum air curtain* downflow velocity profile, i.e., a higher velocity of downflow behind the viewscreen relative to downflow velocity over the work surface.
3. High velocity return air slots shall be located at each end of the front access opening. These slots help to prevent contaminated air from being drawn into the work area along the edges of the side wall and from escaping the work area to the ambient environment.
4. The sliding viewscreen shall be slanted at an angle of 10° from vertical, capable of moving to a fully closed position during shutdown periods.
5. Viewscreen shall be constructed of ½" safety plate glass, with a maximum opening of 17¼" for equipment loading.
6. All biologically contaminated ducts, plenums and work area side walls shall be permanent metal construction and maintained under negative pressure or enclosed within a negative pressure zone.
7. Cabinet shall be capable of automatically handling a 60% minimum increase in filter loading without reducing total air delivery by more than 10%. With use of the speed controller, a 200% increase in airflow shall be attainable. Test data to verify these capabilities shall be available upon request.
8. Interior work area shall be 27¼" high.
9. Cabinet shall have Baker's exclusive UniPressure™ Prewflow Plenum, designed to provide more uniform airflow to the supply filter.
10. Supply and exhaust filters shall be front-loading.
11. A telescoping plenum assembly shall be provided to allow the filters to be directly clamped to the plenum against a closed-cell

- neoprene gasket. Plenum applies force to full perimeter of filters, rather than point force.
12. Complete unit shall be listed as certified by ETL electrical, fire and personal safety.
 13. Sliding sash high velocity air return slots shall be provided along the entire top of the work area to prevent migration of contaminated air behind the glass viewscreen.
 14. Cabinet shall have a microprocessor-based programmable logic controller with membrane control panel mounted on the front of the cabinet facing down toward the user when sitting at the unit.
 15. Unit shall have an audible alarm and a flashing LED to indicate when the sliding viewscreen is in an unsafe position. An alarm mute switch shall be provided on the front-mounted cabinet control panel to allow the operator to mute the alarm tone for brief adjustments. The alarm shall automatically reset after five minutes if the viewscreen remains in an unsafe position.
 16. Intake velocity through the 8" front access opening shall be minimum of 100 FPM.
 17. Cabinet exterior construction: seal panels of 16-gauge, cold-rolled steel and dress panels of 18-gauge, cold-rolled steel, painted PermaWhite™.
 18. Cabinet interior (work area) construction: one-piece 16 gauge, Type 304 stainless steel, with a smooth, ⅝" radius between rear and side walls, and easily cleanable, radiused corners on the work surface tray.
 19. Work area side walls and rear wall shall be one-piece construction. A straight back wall shall be provided to maximize work area and easily accommodate laboratory equipment.
 20. Work area shall be provided with one GFI protected duplex outlet with drip-proof cover and circuit breaker.
 21. Lower front work area airfoil shall be provided to improve access opening containment capability.
 22. Cabinet shall have a unitized drain pan with ⅝" radius on all sides and a fully-removable work surface and work surface supports to facilitate cleaning.
 23. Stainless steel air diffuser and filter protector shall be provided in work area.
 24. Each unit, before shipping, shall have a complete physical test to assure cabinet meets Class II requirements. A copy of this test will be provided with the unit.

25. Speed controller shall automatically compensate for voltage change to maintain constant voltage to motor while allowing for manual adjustments during filter loading.
26. External adjustable damper shall be provided to compensate for changing resistance of exhaust and supply filters.
27. A single power cord and plug shall be provided for electrical power source.
28. One petcock shall be provided on the right wall inside the cabinet. One additional capped penetration shall be provided on the left wall inside the cabinet for addition of a future petcock.
29. All external plumbing connections to the petcocks shall be made through the bottom of the cabinet and not the sides, allowing zero clearance between the unit and the building walls or equipment to its right and left.
30. The unit shall have standard HEPA filters for a protection effectiveness of 99.99% when filtering particles of 0.3 micron size.
31. The unit shall have (optional) ultraviolet light with a shutoff safety feature when the viewscreen is raised.
32. The unit shall have electronic ballasts for UV and fluorescent lighting to provide longer life and lower heat output.
33. The unit is available with an optional stand, which includes telescoping legs that allow the work surface height to be set from 30⅝" to 38⅝".

Warranty

The Baker Company, Inc., expressly represents and warrants all goods (a) to be as specified (and described) in The Baker Company catalogs and literature, and (b) to be free under normal use, service and testing (all as described in The Baker Company catalogs and literature) from defects in material and workmanship for a period of thirty-six months from the invoice date.

The exclusive remedy for any breach or violation of this warranty is as follows: The Baker Company, Inc., will F.O.B. Sanford, Maine, furnish without charge repairs to or replacement of the parts or equipment which proved defective in material or workmanship. No claim may be made for any incidental or consequential damages.

THIS WARRANTY IS EXPRESSLY IN LIEU OF ALL OTHER WARRANTIES, EXPRESSED OR IMPLIED, INCLUDING ANY IMPLIED WARRANTY OF MERCHANTABILITY OR FITNESS FOR A PARTICULAR PURPOSE UNLESS OTHERWISE AGREED IN WRITING SIGNED BY THE BAKER COMPANY. (THE BAKER COMPANY SHALL NOT BE RESPONSIBLE FOR ANY IMPROPER USE, INSTALLATION, SERVICE OR TESTING OF THE GOODS.)

THE BAKER COMPANY

P.O. Drawer E, Sanford, Maine 04073 (207) 324-8773 1-800-992-2537 FAX (207) 324-3869 www.bakerco.com

©2004 The Baker Company