



A Donald **BASIL** Company

Life Science Solutions

The LYNX mission is to provide Animal Care Washing Systems of the highest standards, quality, and reliability in the industry. Our service and customer care will be unmatched

Model 710LX Bedding Dispenser

APPLICATION:

The Bedding Dispenser is a semi-automatic unit designed to dispense bedding materials into two (2) rodent cages (maximum 13" x 13") simultaneously when they are placed into position within the filling area. The dispenser is capable of handling most chip-type, free flowing solid bedding, as commonly used in the animal care industry. The dispensed bedding volume is adjustable to accommodate various depths and sizes of cages.

STANDARD FEATURES:

- All Stainless Steel Construction
- 15 Cubic Feet Bedding Hopper
- Automatic Bedding Transfer
- Operator Control Panel
- Stainless Steel Work Station
- Dust Filtration

OPTIONAL FEATURES:

- Dust Collection System
- Air Compressor
- Seismic Tie Down



SIZE:

Tunnel Opening: 14" high x 27" wide

Overall Size: 93" high x 43" wide x 30" long

Make a Difference...Make it LYNX!

Utilities: 710LX

E	Electrical	120 VAC	Single Phase	60 Hz	30 Amps
V	Vent	4" ID Duct	650 CFM	¾" SP	

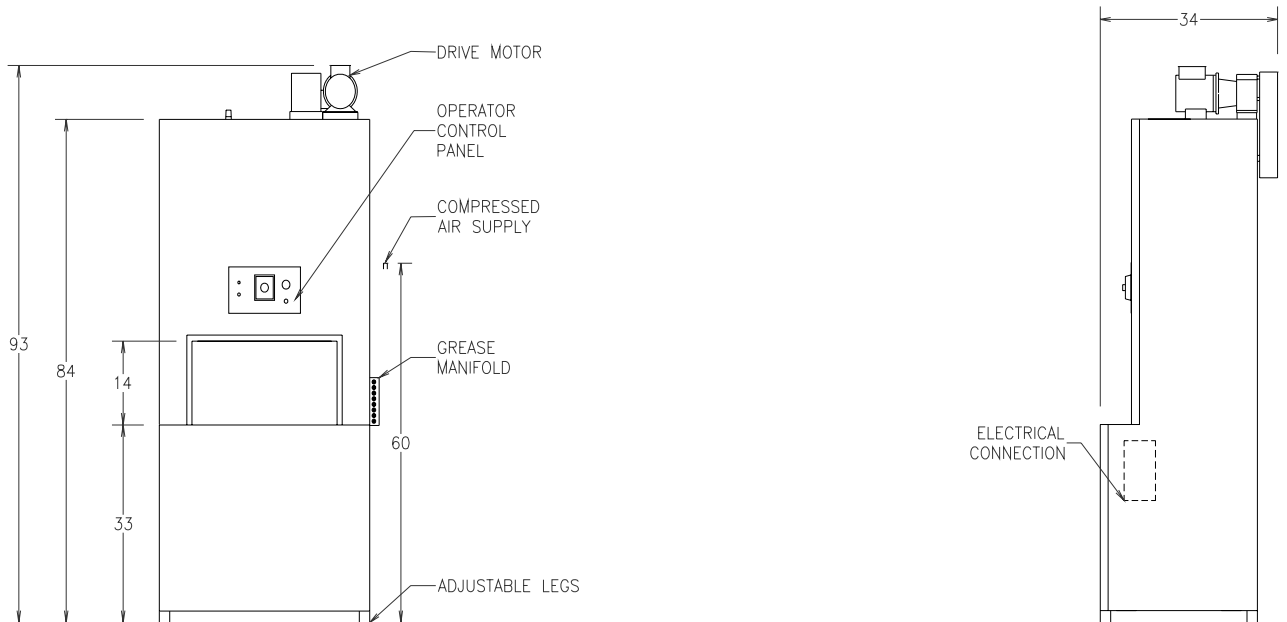
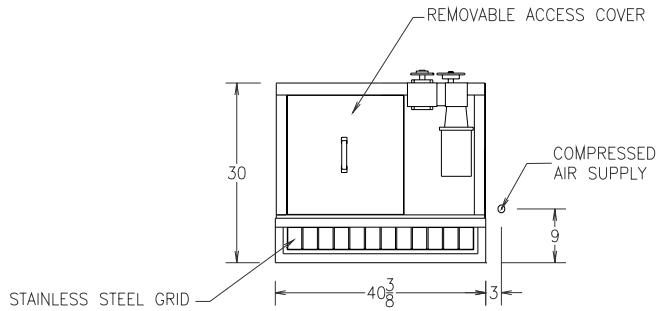

NOTE:

- The selection of certain options could reduce the above stated utilities. Please consult your LYNX representative to discuss your specific requirements.
- Drawing data is for general reference only. Each sized unit and selected options will effect the overall machine size. Obtain certified drawings for design and installation details.
- Specifications are subject to change without notice.



A Donald **BASIL** Company

Life Science Solutions

The LYNX mission is to provide Animal Care Washing Systems of the highest standards, quality, and reliability in the industry. Our service and customer care will be unmatched

Model 724LX Bedding Dispenser

APPLICATION:

The Bedding Dispenser is an automatic, conveyORIZED unit designed to automatically dispense most solid bedding materials into animal cages as they are conveyed through the filling chamber. The bedding volume dispensed into the cages is adjustable to accommodate various bedding depths and sizes of cages.

STANDARD FEATURES:

- All Stainless Steel Construction
- 12 Cubic Foot Bedding Hopper
- Powered Roller Conveyor
- Operator Control Panel
- Clean-out Access Ports
- Load End Water Collection Area

OPTIONAL FEATURES:

- Dust Collection System
- Knock Down Shipment
- Photo-electric Conveyor Stop
- Seismic Tie Down
- Discharge Roller Conveyor
 - 4'-0" long
 - 6'-0" long
 - 8'-0" long



SIZE:

Tunnel Opening: 12" high x 30" wide

Overall Size: 67" high x 74" wide x 96" long

Make a Difference...Make it LYNX!

Utilities: 724LX

E	Electrical	30A-110V	
D	Drain	2" Floor Drain	
V	Vent	4" ID Duct	650 CFM

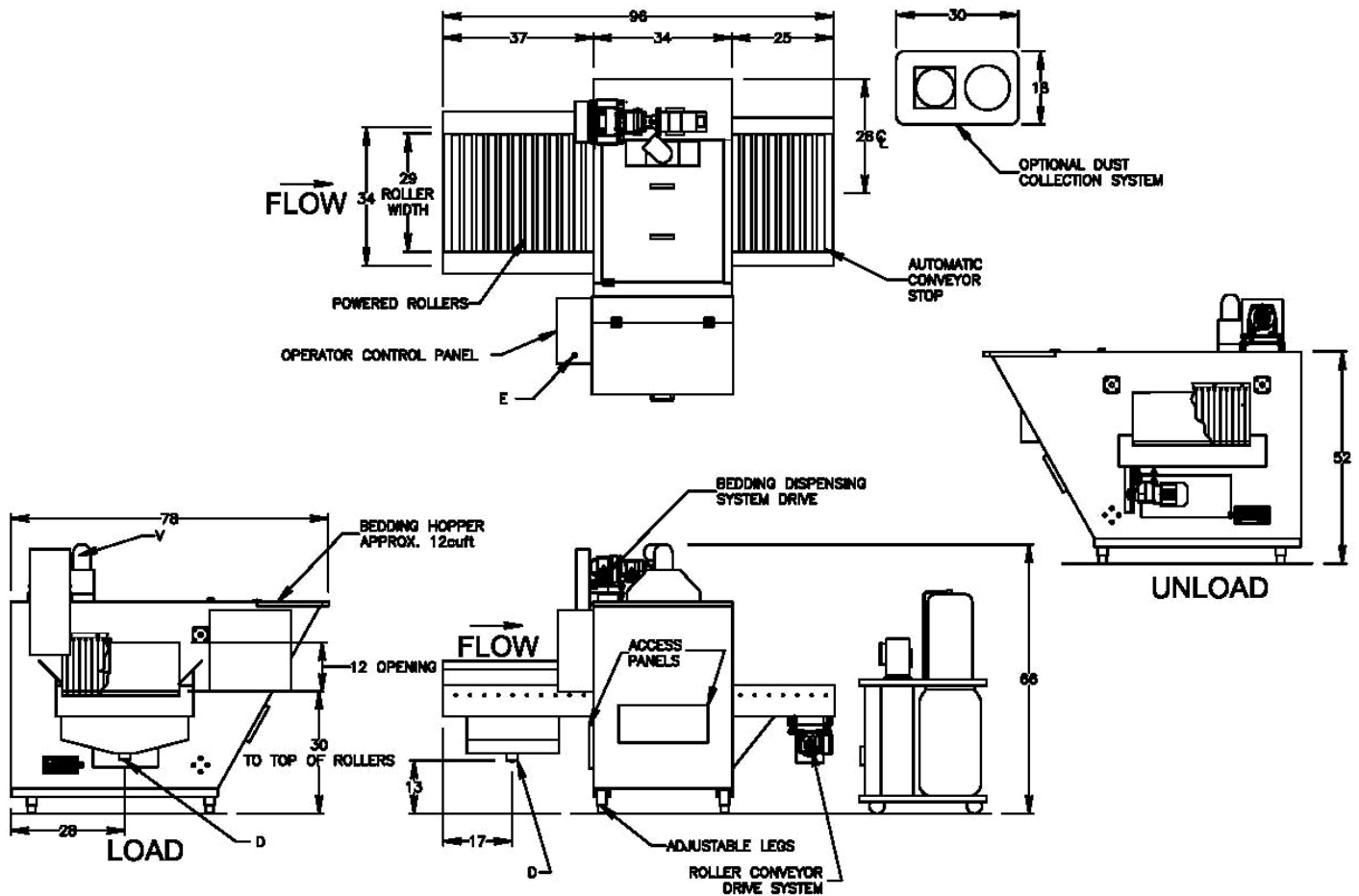

NOTE:

- The selection of certain options could reduce the above stated utilities. Please consult your LYNX representative to discuss your specific requirements.
- Drawing data is for general reference only. Each sized unit and selected options will effect the overall machine size. Obtain certified drawings for design and installation details.
- Specifications are subject to change without notice.



A Donald **BASIL** Company

Life Science Solutions

The LYNX mission is to provide Animal Care Washing Systems of the highest standards, quality, and reliability in the industry. Our service and customer care will be unmatched

Model 730LX Bedding Dispenser

APPLICATION:

The Bedding Dispenser is an automatic, conveyORIZED unit designed to automatically dispense most solid bedding materials into animal cages as they are conveyed through the filling chamber. The bedding volume dispensed into the cages is adjustable to accommodate various bedding depths and sizes of cages.

STANDARD FEATURES:

- All Stainless Steel Construction
- 12 Cubic Foot Bedding Hopper
- Powered Roller Conveyor
- Operator Control Panel
- Clean-out Access Ports
- Load End Water Collection Area

OPTIONAL FEATURES:

- Dust Collection System
- Knock Down Shipment
- Photo-electric Conveyor Stop
- Seismic Tie Down
- Discharge Roller Conveyor
 - 4'-0" long
 - 6'-0" long
 - 8'-0" long



SIZE:
Tunnel Opening: 12" high x 36" wide
Overall Size: 67" high x 80" wide x 96" long

Make a Difference...Make it LYNX!

Utilities: 730LX

E	Electrical	30A – 110V	
D	Drain	2" Floor Drain	
V	Vent	4" ID Duct	650 CFM

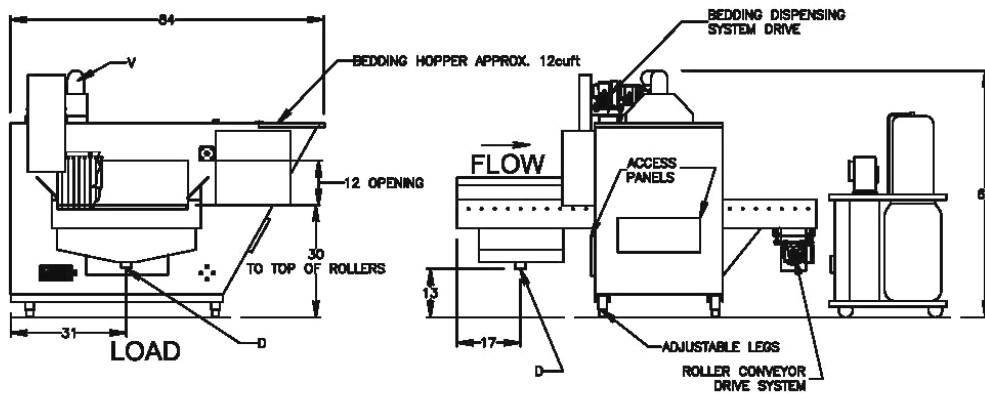
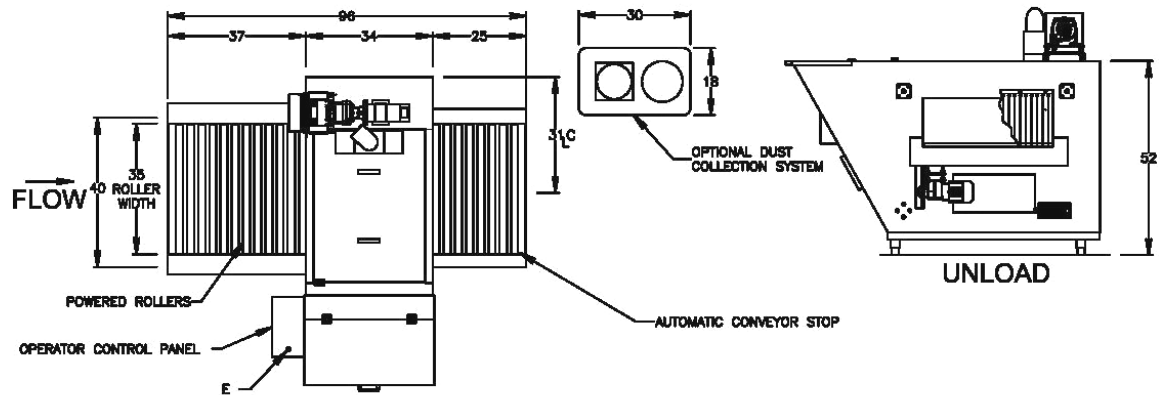

NOTE:

- The selection of certain options could reduce the above stated utilities. Please consult your LYNX representative to discuss your specific requirements.
- Drawing data is for general reference only. Each sized unit and selected options will effect the overall machine size. Obtain certified drawings for design and installation details.
- Specifications are subject to change without notice.



A Donald **BASIL** Company

Life Science Solutions

The LYNX mission is to provide Animal Care Washing Systems of the highest standards, quality, and reliability in the industry. Our service and customer care will be unmatched

Model 736LX Bedding Dispenser

APPLICATION:

The Bedding Dispenser is an automatic, conveyORIZED unit designed to automatically dispense most solid bedding materials into animal cages as they are conveyed through the filling chamber. The bedding volume dispensed into the cages is adjustable to accommodate various bedding depths and sizes of cages.

STANDARD FEATURES:

- All Stainless Steel Construction
- 12 Cubic Foot Bedding Hopper
- Powered Roller Conveyor
- Operator Control Panel
- Clean-out Access Ports
- Load End Water Collection Area

OPTIONAL FEATURES:

- Dust Collection System
- Knock Down Shipment
- Photo-electric Conveyor Stop
- Seismic Tie Down
- Discharge Roller Conveyor
 - 4'-0" long
 - 6'-0" long
 - 8'-0" long



SIZE:
Tunnel Opening: 12" high x 42" wide
Overall Size: 67" high x 86" wide x 96" long

Make a Difference...Make it LYNX!

Utilities: 736LX

E	Electrical	30A – 110V	
D	Drain	2" Floor Drain	
V	Vent	4" ID Duct	650 CFM

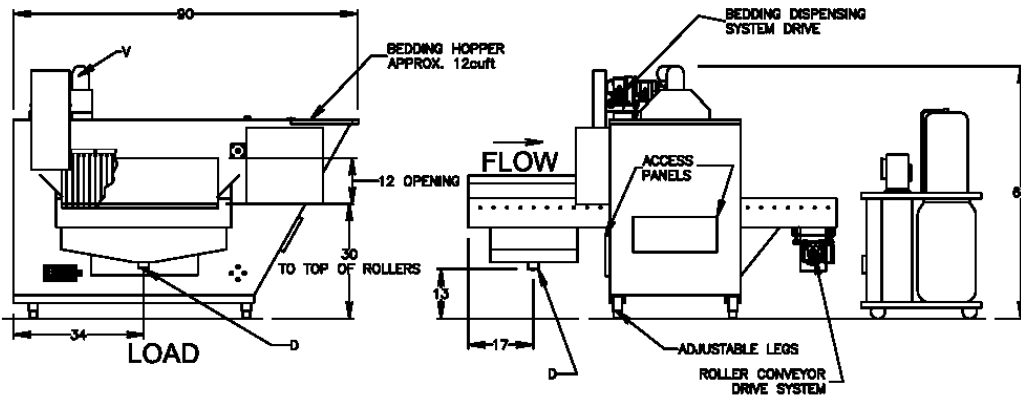
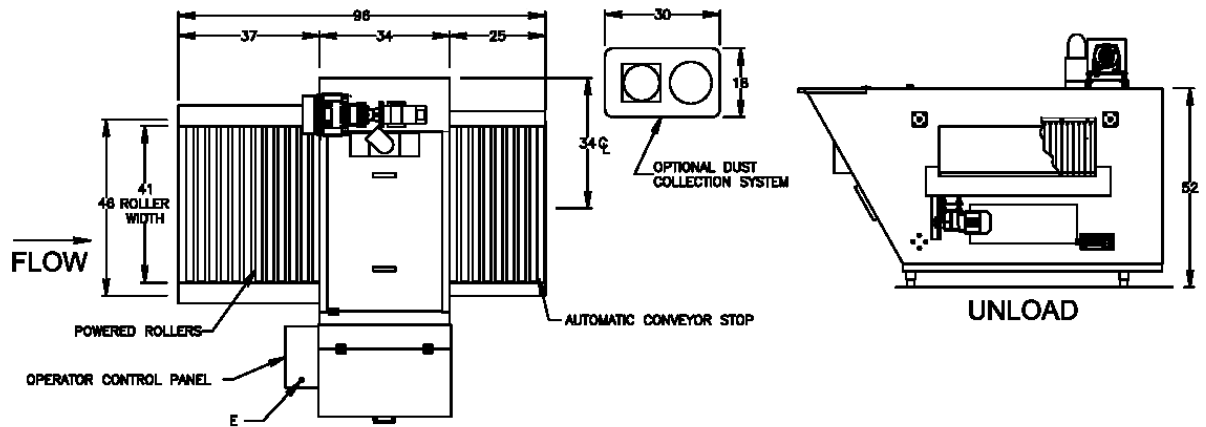

NOTE:

- The selection of certain options could reduce the above stated utilities. Please consult your LYNX representative to discuss your specific requirements.
- Drawing data is for general reference only. Each sized unit and selected options will effect the overall machine size. Obtain certified drawings for design and installation details.
- Specifications are subject to change without notice.



A Donald **BASIL** Company

Life Science Solutions

The LYNX mission is to provide Animal Care Washing Systems of the highest standards, quality, and reliability in the industry. Our service and customer care will be unmatched

Model 742LX Bedding Dispenser

APPLICATION:

The Bedding Dispenser is an automatic, conveyORIZED unit designed to automatically dispense most solid bedding materials into animal cages as they are conveyed through the filling chamber. The bedding volume dispensed into the cages is adjustable to accommodate various bedding depths and sizes of cages.

STANDARD FEATURES:

- All Stainless Steel Construction
- 12 Cubic Foot Bedding Hopper
- Powered Roller Conveyor
- Operator Control Panel
- Clean-out Access Ports
- Load End Water Collection Area

OPTIONAL FEATURES:

- Dust Collection System
- Knock Down Shipment
- Photo-electric Conveyor Stop
- Seismic Tie Down
- Discharge Roller Conveyor
 - 4'-0" long
 - 6'-0" long
 - 8'-0" long



SIZE:

Tunnel Opening: 12" high x 48" wide

Overall Size: 67" high x 92" wide x 96" long

Make a Difference...Make it LYNX!

Utilities: 742LX

E	Electrical	30A – 110V	
D	Drain	2" Floor Drain	
V	Vent	4" ID Duct	650 CFM

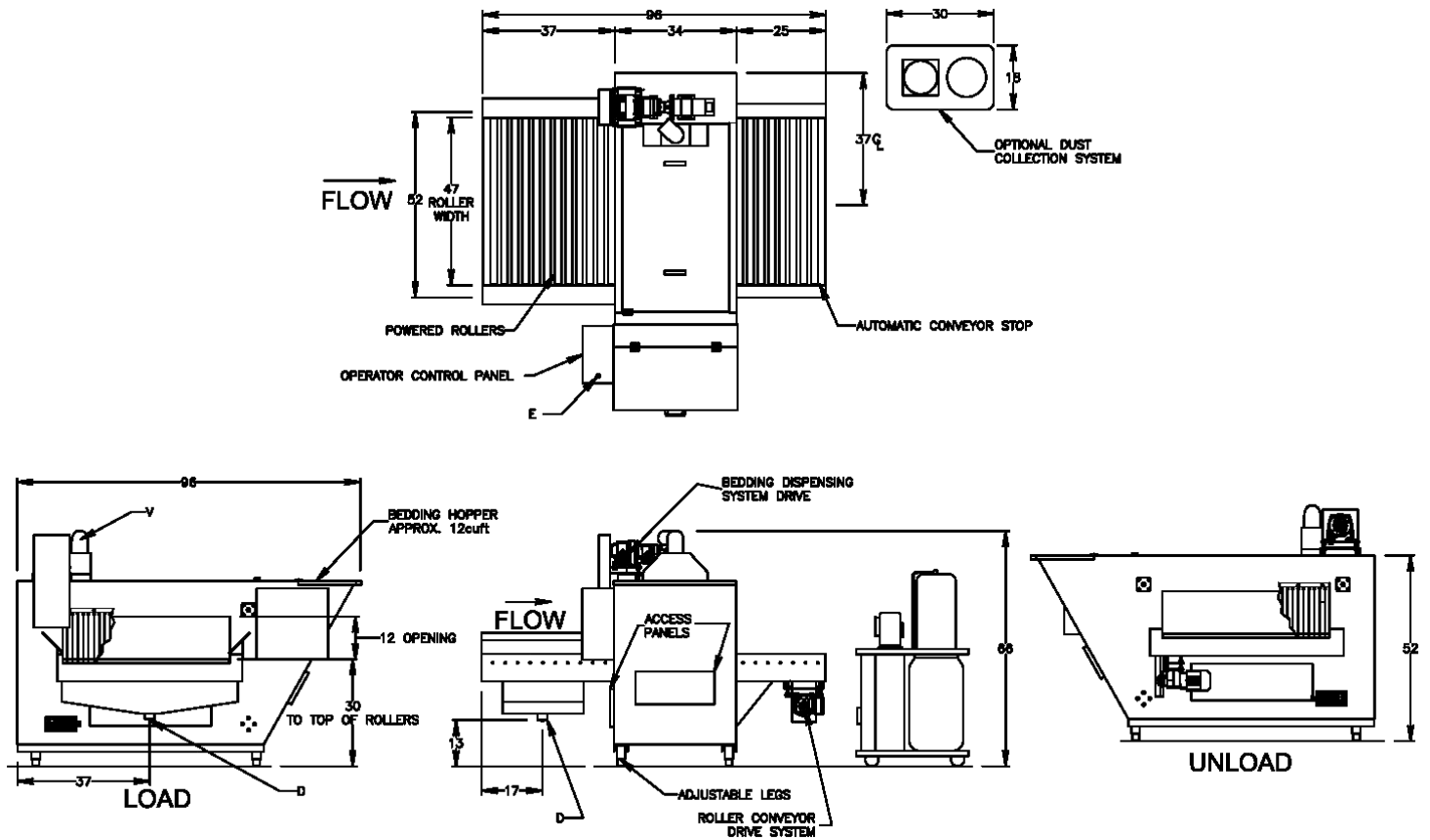

NOTE:

- The selection of certain options could reduce the above stated utilities. Please consult your LYNX representative to discuss your specific requirements.
- Drawing data is for general reference only. Each sized unit and selected options will effect the overall machine size. Obtain certified drawings for design and installation details.
- Specifications are subject to change without notice.



A Donald **BASIL** Company

Life Science Solutions

The LYNX mission is to provide Animal Care Washing Systems of the highest standards, quality, and reliability in the industry. Our service and customer care will be unmatched

Model 748LX Bedding Dispenser

APPLICATION:

The Bedding Dispenser is an automatic, conveyORIZED unit designed to automatically dispense most solid bedding materials into animal cages as they are conveyed through the filling chamber. The bedding volume dispensed into the cages is adjustable to accommodate various bedding depths and sizes of cages.

STANDARD FEATURES:

- All Stainless Steel Construction
- 12 Cubic Foot Bedding Hopper
- Powered Roller Conveyor
- Operator Control Panel
- Clean-out Access Ports
- Load End Water Collection Area

OPTIONAL FEATURES:

- Dust Collection System
- Knock Down Shipment
- Photo-electric Conveyor Stop
- Seismic Tie Down
- Discharge Roller Conveyor
 - 4'-0" long
 - 6'-0" long
 - 8'-0" long



SIZE:

Tunnel Opening: 12" high x 54" wide

Overall Size: 67" high x 98" wide x 96" long

Make a Difference...Make it LYNX!

Utilities: 748LX

E	Electrical	30A – 110V	
D	Drain	2" Floor Drain	
V	Vent	4" ID Duct	650 FM

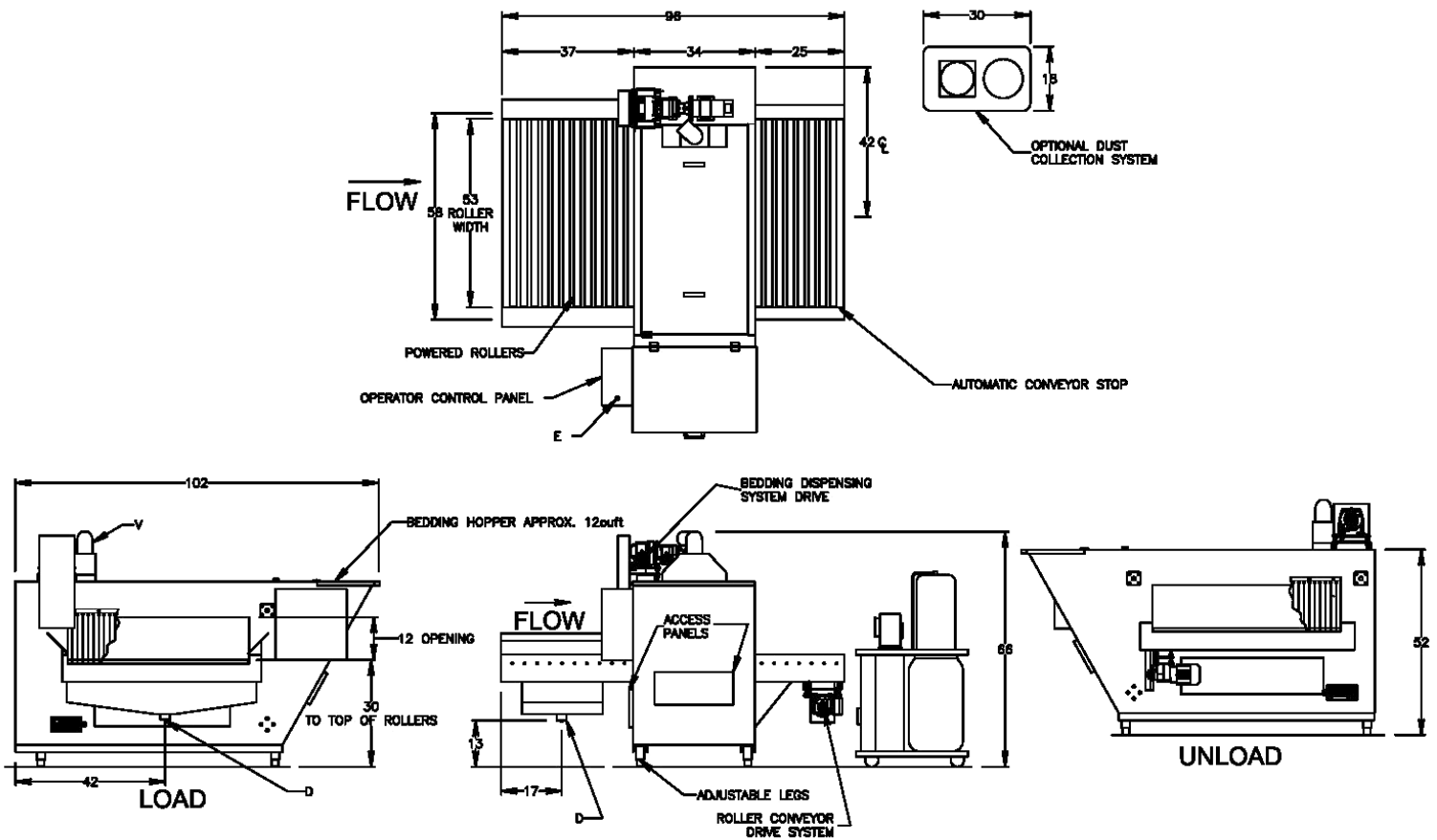

NOTE:

- The selection of certain options could reduce the above stated utilities. Please consult your LYNX representative to discuss your specific requirements.
- Drawing data is for general reference only. Each sized unit and selected options will effect the overall machine size. Obtain certified drawings for design and installation details.
- Specifications are subject to change without notice.